

IP66

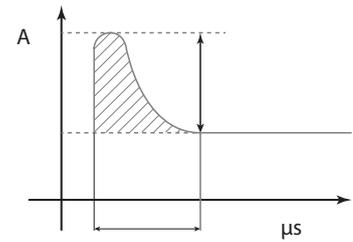

ROAD [5] MINI				
3 LEDS	6,8	MAX 15 m	0,15m ²	0,05 m ²
6 LEDS	7	MAX 15 m	0,15m ²	0,05 m ²
ROAD [5] MEDIUM				
9 LEDS	8,5	MAX 15 m	0,19m ²	0,06 m ²
12 LEDS	8,7	MAX 15 m	0,19m ²	0,06 m ²
15 LEDS	8,9	MAX 15 m	0,19m ²	0,06 m ²
18 LEDS	9,1	MAX 15 m	0,19m ²	0,06 m ²

ROAD [5]			<i>I</i> _{LED} (A)		
			ta 50°C	ta 45°C	ta 40°C
STAND-ALONE / DIMMABLE 1-10V & BI-POWER WITH SELF LEARNING	MINI 1A	3 LED	Max. 0,85	Max. 0,85	Max. 1,0
		6 LED	Max. 0,85	Max. 0,85	Max. 1,0
	MINI 0,9A STAND-ALONE	6 LED	/	/	Max. 0,9
	MEDIUM 1A	9 LED	Max. 0,85	Max. 0,85	Max. 1,0
		12 LED	Max. 0,85	Max. 0,85	Max. 1,0
		15 LED	Max. 0,7	Max. 0,7	Max. 0,85
		18 LED	Max. 0,7	Max. 0,7	Max. 0,85
	MINI 0,7A	3 LED	Max. 0,7	Max. 0,7	Max. 0,7
		6 LED	Max. 0,7	Max. 0,7	Max. 0,7
	MEDIUM 0,7A	9 LED	Max. 0,7	Max. 0,7	Max. 0,7
12 LED		Max. 0,7	Max. 0,7	Max. 0,7	
15 LED		Max. 0,7	Max. 0,7	Max. 0,7	
18 LED		Max. 0,7	Max. 0,7	Max. 0,7	
DALI	MINI 0,7A	3 LED	Max. 0,7	Max. 0,7	Max. 0,7
		6 LED	Max. 0,7	Max. 0,7	Max. 0,7
	MEDIUM 0,7A	9 LED	Max. 0,7	Max. 0,7	Max. 0,7
		12 LED	Max. 0,7	Max. 0,7	Max. 0,7
		15 LED	Max. 0,7	Max. 0,7	Max. 0,7
		18 LED	Max. 0,7	Max. 0,7	Max. 0,7



	<i>I</i> _{LED} (mA)	Inrush Current Peak and Width
ROAD [5] MINI		
3 LEDS	350	5A/50µs
3 LEDS	700	5A/50µs
3 LEDS	1000	27A/265µs
6 LEDS	700	35A/1000µs
6 LEDS	1000	35A/1000µs
ROAD [5] MINI STAND-ALONE		
3 LEDS	350	5A/50µs
3 LEDS	700	5A/50µs
3 LEDS	1000	5A/50µs
6 LEDS	700	5A/50µs
6 LEDS	900	5A/50µs
ROAD [5] MEDIUM		
9 LEDS	700	35A/1000µs
9 LEDS	1000	53A/300µs
12 LEDS	700	53A/300µs
12 LEDS	1000	53A/300µs
15 LEDS	700	53A/300µs
15 LEDS	850	106A/300µs
18 LEDS	700	53A/300µs
18 LEDS	850	106A/300µs



STREET OPTICS		CYCLE AND PEDESTRIAN OPTIC
W	H	
4,3 m	4,3 m	2,5 m

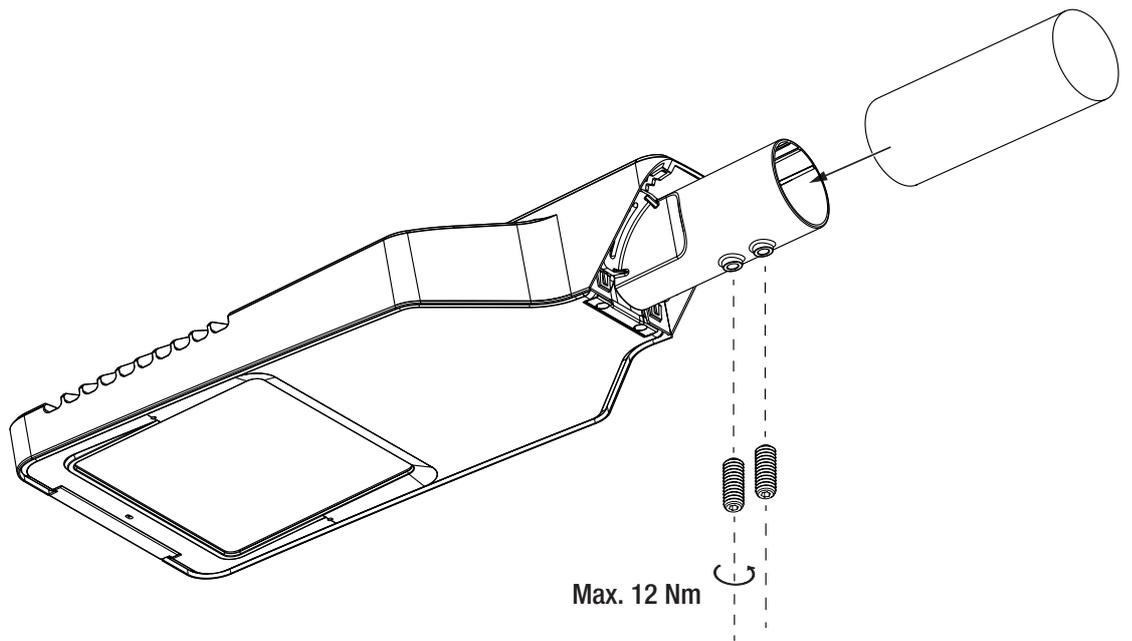
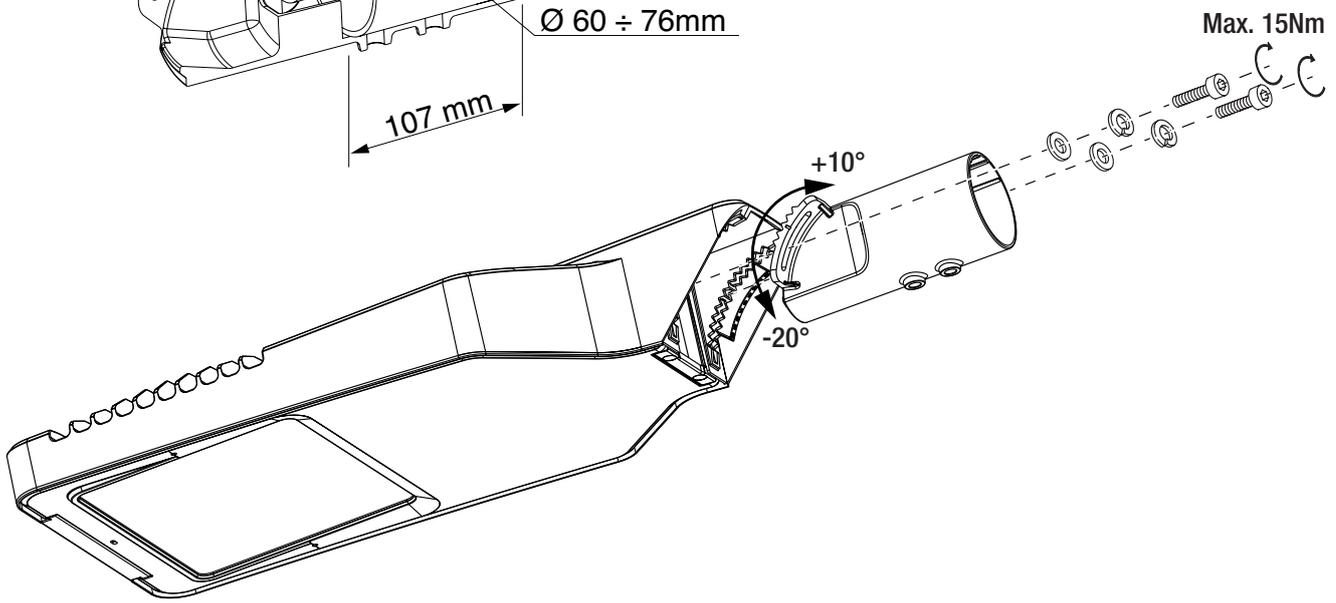
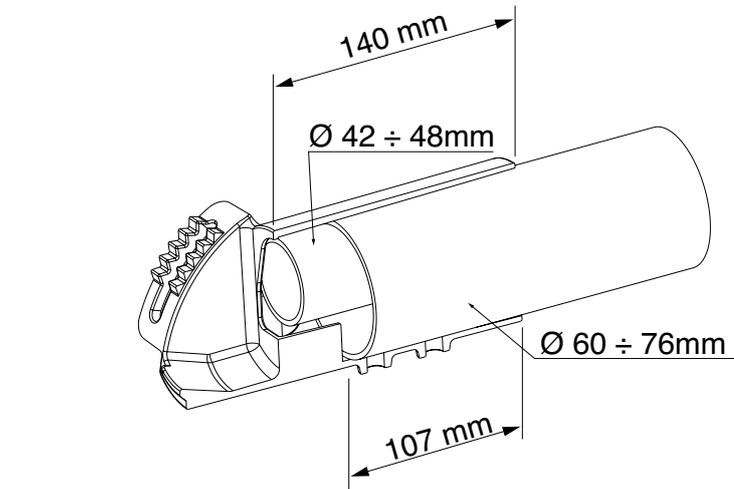
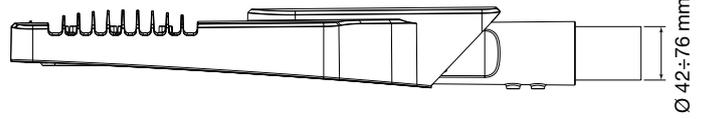

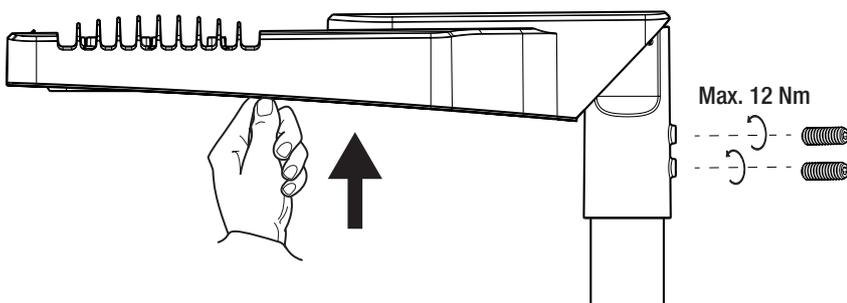
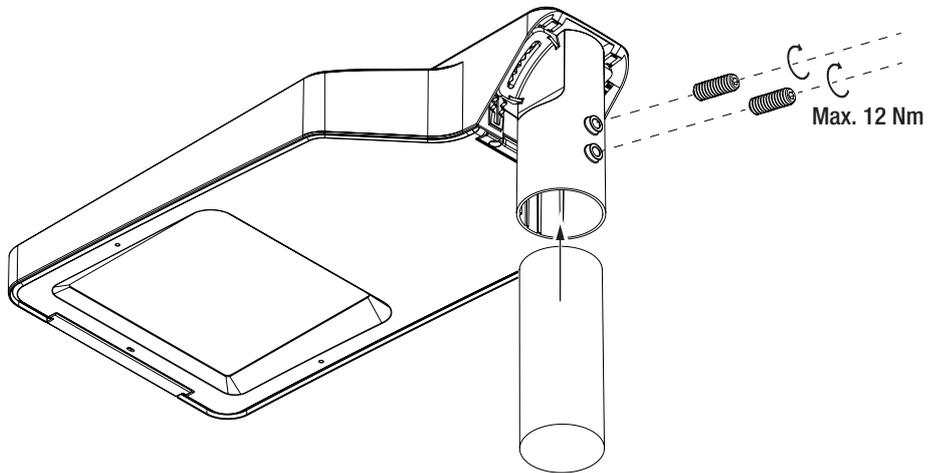
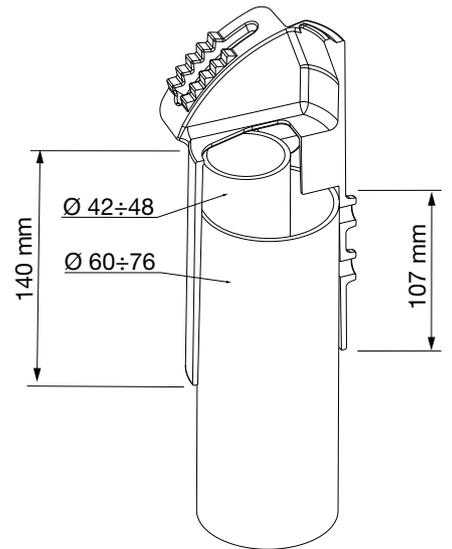
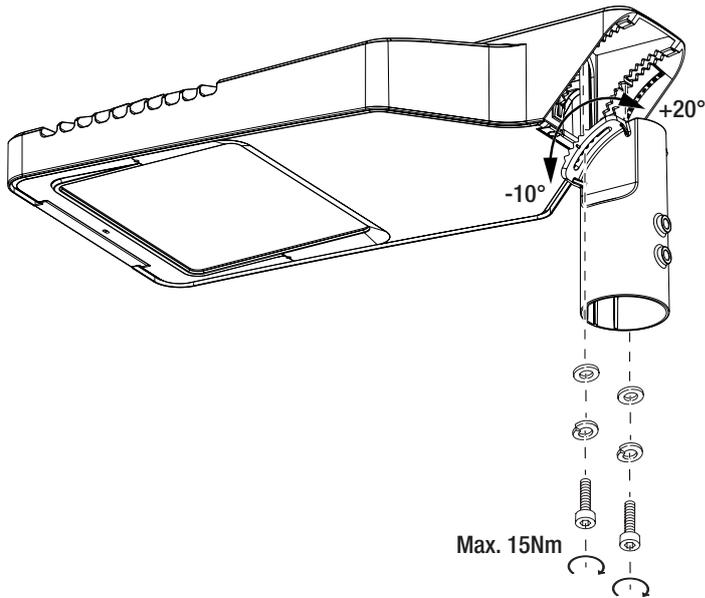
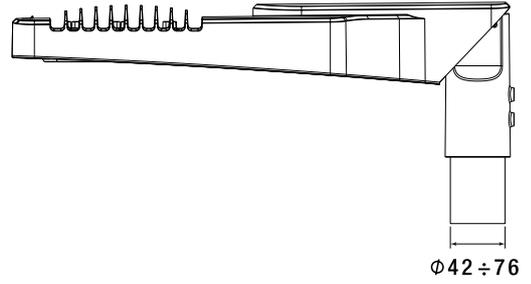

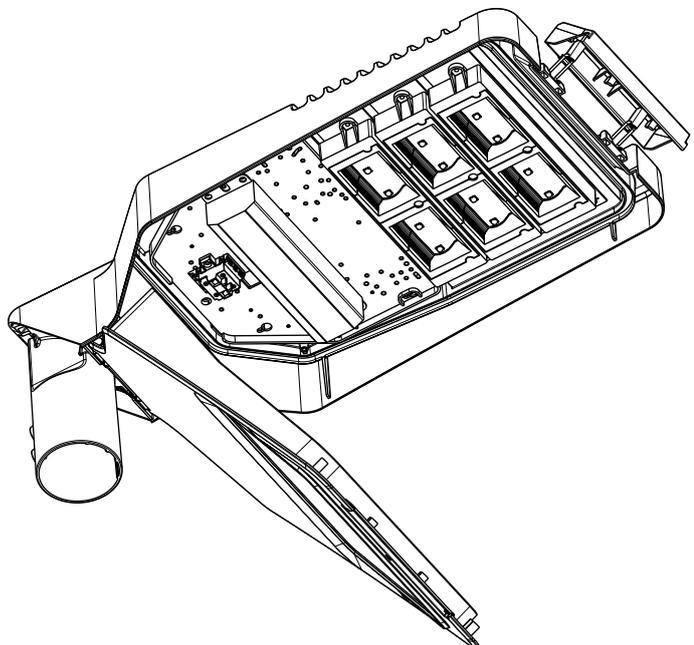
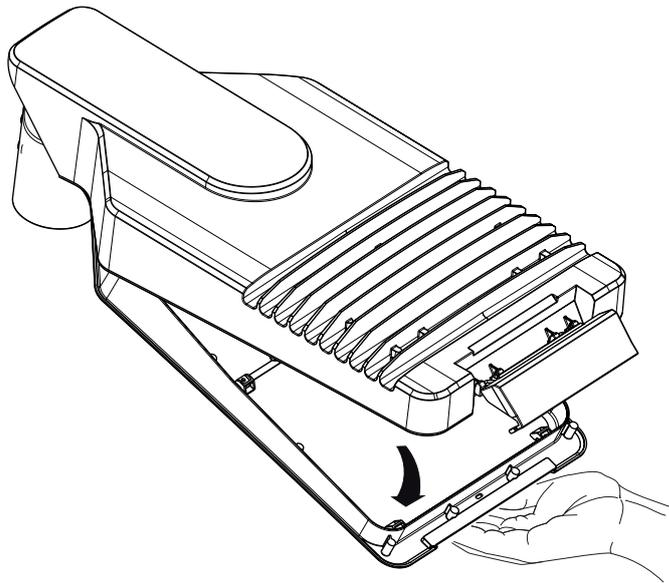
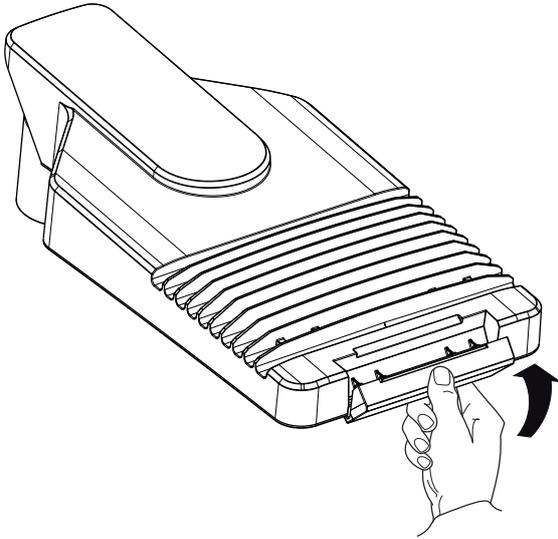

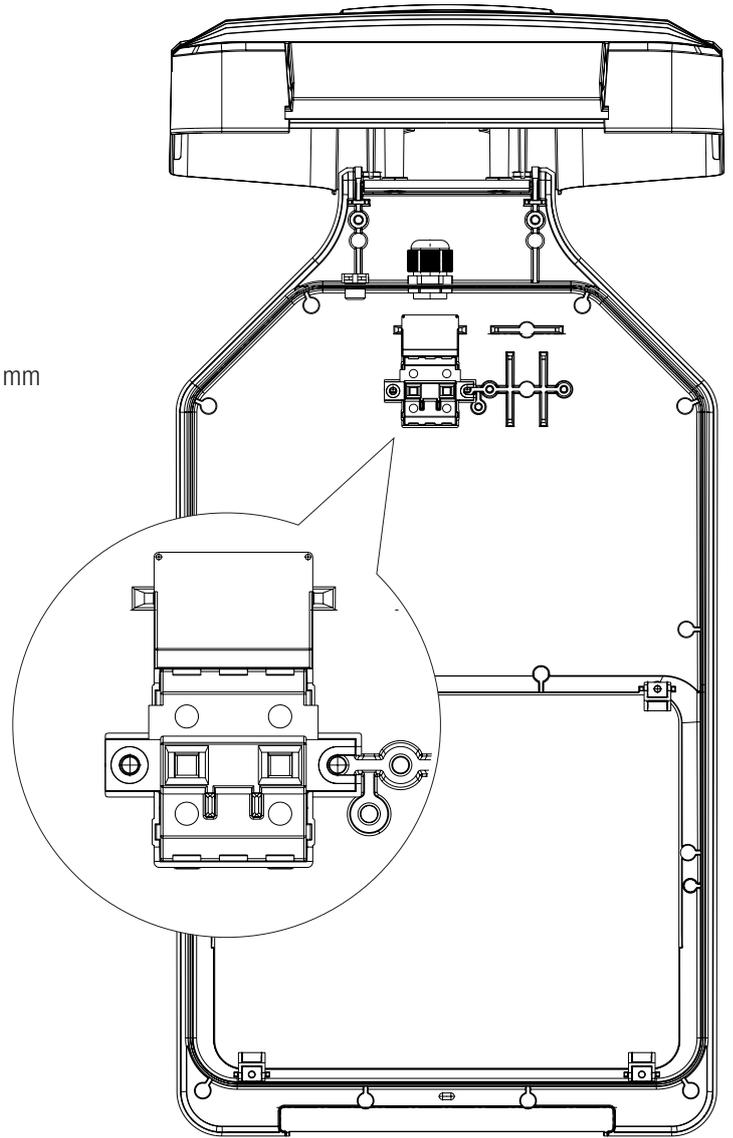
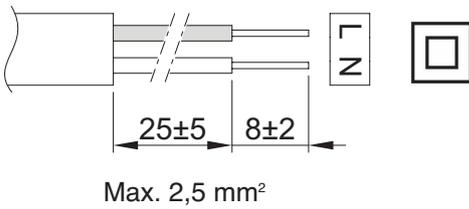
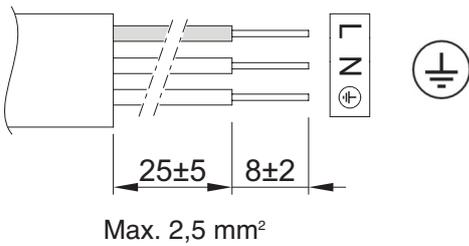
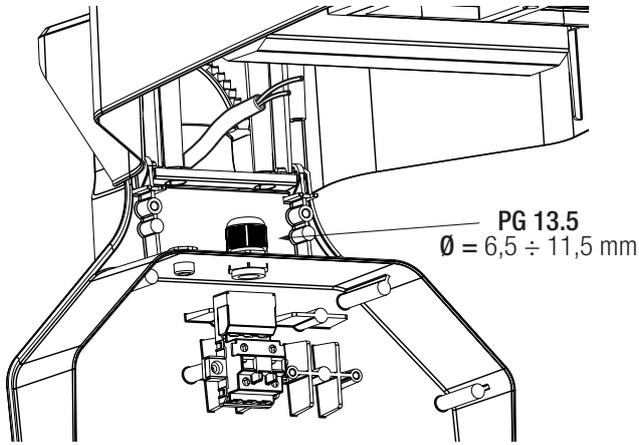

BI-POWER

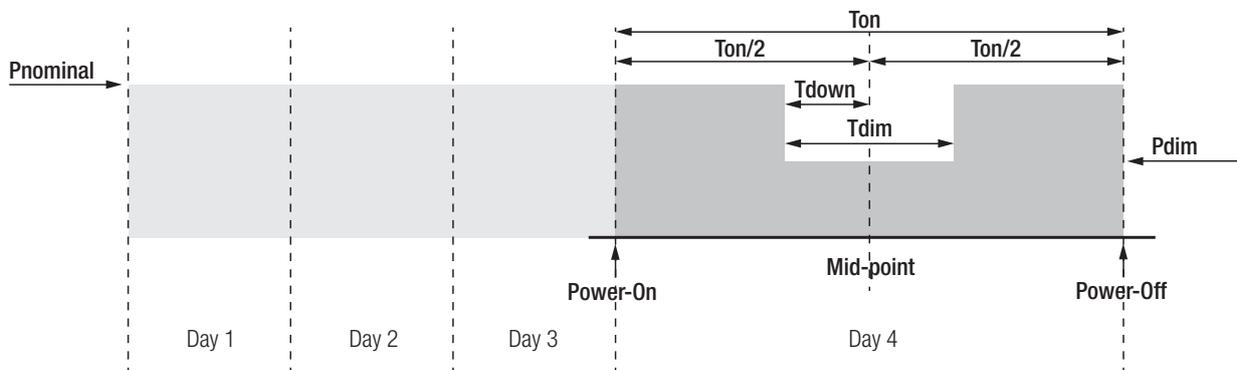

Dim Level (%)	T-dim (hrs)	T-down (hrs)	After Midpoint (hrs)
50	5	1	4

