

**KNX Secure 1-channel 500VA / 2-channel 300VA
universal dimmer actuator - DIN rail mounting**



GW A9321



GW A9322

Technical Manual

Contents

1	Introduction	3
2	Application.....	4
2.1	Association limits	4
3	“Main” menu	5
3.1	Parameters	5
4	“Channel X settings” menu	6
4.1	Parameters	6
5	“Channel x switching” menu.....	13
5.1	Parameters	13
6	“Channel x stairs light” menu	17
6.1	Parameters	17
7	“Channel X relative brightness dimming” menu.....	22
7.1	Parameters	22
8	“Channel X absolute brightness dimming” menu.....	24
8.1	Parameters	24
9	“Channel x blinking” menu	27
9.1	Parameters	27
10	“Channel x Logic” menu.....	30
10.1	Parameters	30
11	“Channel x scenes” menu	35
11.1	Parameters	35
12	“Channel x forced positioning” menu	38
12.1	Parameters	38
13	“Channel x block” menu	41
13.1	Parameters	41
14	“Channel x slave mode” menu	44
14.1	Parameters	44
15	“Channel x counter” menu	47
15.1	Parameters	47
16	“Channel X status information” menu	50
16.1	Parameters	50
17	Behaviour in the case of bus/230V voltage drop/recovery - front button keys - function priority	52
17.1	Behaviour in the case of bus voltage drop and recovery.....	52
17.2	Behaviour in the case of 230V voltage drop and recovery	52
17.3	Front button key operation	52
17.4	Priority of the functions	52
18	Alarm signalling.....	55
19	Factory reset / signalling of ETS download in progress / application deleted	57
20	Communication objects.....	58

1 Introduction

This manual explains the functions of the **KNX Secure 1-channel 500VA universal dimmer actuator - DIN rail mounting** (GW A9321) device and the **KNX Secure 2-channels 300VA universal dimmer actuator - DIN rail mounting** (GW A9322) device and how they are set and configured with the aid of the ETS configuration software.

This manual provides explanations of the configuration parameters in reference to the 2-channel GW A9322 model, which are the same as those relative to the 1-channel GW A9321 device.

The KNX Secure universal dimmer actuator - DIN rail mounting, is used to command and adjust 230V AC incandescent and halogen lamps, inductive loads (low voltage halogen lamps, via winding transformers), capacitive loads (low voltage halogen lamps, via electronic transformers), 230V AC LED lamps and CFL lamps with dimmer function.

The dimmer actuator is powered from the 230V AC line (taken from channel-1 phase), so as to allow the load to be commanded locally even in the absence of the KNX bus voltage. The device has push-buttons and front LEDs for commanding the outputs and indicating their status, and for selecting the type of load and a LED for signalling faults. The dimmer actuator is used to switch the connected load on and off, adjust the degree of light intensity, perform timed commands, priority commands and locking activation commands for forcing the output status, memorise and execute scenes, and manage the slave function so a KNX master device can control the light intensity.

The dimmer actuator is assembled on a DIN rail, inside electric boards or junction boxes.

The device supports KNX Data Secure: this technology enhances the security of a KNX installation both during start up and during normal operation, thanks to the exchange of encrypted telegrams.

2 Application

The device is configured with the ETS software, to perform the following functions:

On-Off switching

- Setting the degree of light intensity for the execution of the ON switchover command

Relative light adjustment

- Parametrisation of the maximum and minimum adjustment threshold.
- Parametrisation of the relative adjustment speeds between 0% and 50%, and between 50% and 100%

Absolute light adjustment

- Setting the mode for reaching the required light intensity (via a ramp or jump to the value)
- Parametrisation of the ramp adjustment speed 0% - 100%

Scenes

- Memorising and activating 8 scenes (value 0 - 63)
- Enabling/disabling of scene learning from bus

Priority command (forcing)

- Setting the degree of light intensity with forcing ON activation
- Setting the forcing status at bus voltage recovery

Timed switching (stairs light)

- Parametrisation of light value during timing
- Setting the activation time
- Setting the pre-warning time
- Parametrisation of behaviour when a timed activation command is received with timing already active
- Stairs light activation time setting from bus

Block function

- Parametrisation of the block activation value, behaviour when block is active, and behaviour when block is deactivated
- Setting the block object value upon download and upon bus voltage recovery

“Slave” mode for device control via the bus

- Setting the monitoring time and dimmer behaviour in safe operating mode
- Parametrisation of the slave mode value upon download and upon voltage recovery

Logical functions

- Logic operation AND/NAND/OR/NOR with command object and result object of logic operation
- Logic operations AND/NAND/OR/NOR/XOR/XNOR up to 8 logic inputs
- Setting the NOT operation on the 8 inputs

For all the command objects, the following operations are possible:

- Setting the mode for reaching the required light intensity (via a ramp or jump to the value)
- Parametrisation of the ramp adjustment speed 0% - 100%
- Setting the delay for switch-on and switch-off

Other functions

- Parametrisation of the output behaviour upon failure and recovery of bus voltage
- Setting the transmission of information concerning the ON/OFF status and the current light intensity percentage value
- Setting the transmission of information concerning overloads
- Setting the transmission of information concerning the absence of a 230V voltage (with bus voltage present)
- Enabling the channel counter for counting the period the channel is on or off
- Setting the local button key operation

2.1 Association limits

Maximum number of group addresses:	254
Maximum number of associations:	254

This means that up to 254 group addresses can be defined, and up to 254 associations can be made between communication objects and group addresses.

3 “Main” menu

The **Main** menu contains the parameters used to enable the different functions implemented by the device and to set the main operating parameters.

*Note: in the 1-channel dimmer version - KNX 1-channel 500VA universal dimmer actuator - DIN rail mounting (GW A9321) – this menu is not present and the parameter “Alarms and status information transmission delay at start” was added to the menu **Channel x settings**.*

The basic structure of the menu is as follows:

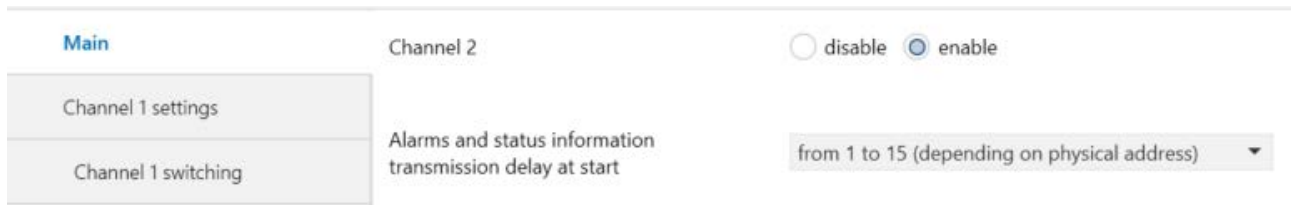

Fig. 3.1

3.1 Parameters

➤ 3.1.1 Channel 2

Channel 1 is always enabled. The parameter “**Channel 2**” is used to visualise and configure all the operating parameters of the relative channel. The values that can be set for these parameters are:

- disable
- **enable** (default value)

By selecting the value **disable**, the maximum load power connected to channel 1 is 500W; selecting **enable**, displays the menu **Channel 2 settings** whereas the maximum power that can be managed by each of the two channels is 300W.

➤ 3.1.2 Alarms and status information transmission delay at start

It is possible to determine the delay upon transmission on the bus of the status information (light intensity values, on/off status and alarm feedback) for both channels via the parameter “**Alarms and status information transmission delay at start**”. The parameter can have the following values:

- **from 1 to 15 (depending on physical address)** (default value)
- 1
- 2
- 3
- 4
- 5
- 6
- 7
- 8
- 9
- 10
- 11
- 12
- 13
- 14
- 15

4 “Channel X settings” menu

For the sake of simplicity, the items that make up the menus **Channel 1 settings** and **Channel 2 settings** will be described only once in the following chapters (in reference to the generic menu **Channel x settings**) as all these menus have the same items.

The **Channel x settings** menu contains the parameters that define the behaviour of channel x beyond the specific functions implemented by the dimmer.

The basic structure of the menu is as follows:

Main	Connected load control type	<input type="radio"/> trailing edge <input checked="" type="radio"/> leading edge
Channel 1 settings	Connected load trigger type	<input checked="" type="radio"/> soft start <input type="radio"/> fast start
Channel 1 switching	Maximum dimming threshold	100% ▼
Channel 1 stairs light	Minimum dimming threshold	0% ▼
Channel 1 relative brightness dimming	Brightness reaching for on/off, stairs light, forcing, block, blinking, slave	<input checked="" type="radio"/> with jump to value <input type="radio"/> with ramp
Channel 1 absolute brightness dimming		
Channel 1 blinking	Channel status at bus voltage recovery	as before voltage drop ▼
Channel 1 logic	Channel status at 230V voltage recovery	follows last command received ▼
Channel 1 scenes	Local push button behaviour	single push button dimmer test ▼
Channel 1 forced positioning	Overload alarm warning	sending on change ▼
Channel 1 block	230V voltage alarm feedback	sending on change ▼
Channel 1 slave mode	Device overheating alarm feedback	sending on change ▼

Fig. 4.1

4.1 Parameters

➤ 4.1.1 Connected load control type

Each channel of the universal dimmer is designed to be able to manage any type of load; during programming, the type of output control must be defined based on the load connected to the terminals associated with channel x, in order to correctly control the load itself.

The maximum power each channel can manage changes depending on the load selected, as summarised on the instruction sheet.

The parameter “**Connected load control type**” is used to select the control to be used for correctly control the load itself; the values that can be set are:

- trailing edge
- **leading edge** (default value)

The control mode is usually indicated by the manufacturer of the load to be controlled. If the control selected is not the correct one, neither the device nor the load will be damaged; the light will flicker during dimming.

➤ 4.1.2 Connected load trigger type

In addition to the control mode, also the mode for triggering the load must be defined, especially for the type of load that, when off, must be brought to maximum light intensity for a certain period of time before being dimmed. The parameter “**Connected load trigger type**” is used to define the load trigger mode; the values that can be set are:

- **soft start (default value)**
When off, the load will be switched on with a soft-start ramp from minimum to the desired value; this effect will be hardly noticed by the user.
- **fast start**
When off, the load will be switched on to maximum and will then perform the decreasing control ramp down to the desired value; also in this case, the control ramp will be hardly noticed by the user.

Selecting the value **fast start** displays the parameter “**Residence time at 100% for load trigger [ms]**”, which is used to set the residence time of the load at 100% for triggering the load before starting the dimming ramp to the desired value; the values that can be set are:

- from 1 to 65535 in steps of 1, **(default value 2000)**

The control and trigger type can be changed if necessary by following the manual procedure indicated below:

Accessing configuration mode:

- press the programming button key: the red programming LED lights up
- press the CH1 and Load 1 control push-buttons or the CH2 and Load 2 control push-buttons simultaneously for at least 1 second (there is only one configuration mode and it is always activated for both channels)
- wait for the red LED for programming to flash three times

Once you have accessed the configuration phase, all the channels are deactivated (light intensity value 0%) while the CH1 and CH2 LEDs show the parameter to be configured. The Load 1 and Load 2 LEDs show the current parameter configuration status. Refer to the table:

#	Parameter	CHx LED	Values	Load x LED
1	Type of load	fixed red	trailing edge	flashing red (1 Hz)
			leading edge	fixed red
2	Trigger type	fixed yellow	soft start	fixed yellow
			fast start	flashing yellow (1 Hz)

You can modify the setting of the channel 1 parameter using the Load 1 button key and the channel 2 parameter using the Load 2 button key.

You can confirm the setting of one parameter and then set the next one by pressing the CH1 push-button for channel 1 and the CH2 push-button for channel 2.

Quitting configuration mode:

- to save the new settings: press the programming push-button
- to quit without saving the settings: wait 10 seconds (from the last pressing of a push-button).

The end of configuration mode is signalled by the red LED for programming flashing three times and then switching off.

When you have quit the configuration phase, the channels will be restored to the status they had prior to that phase and any messages from the bus are processed.

If the type of trigger is changed from “soft start” to “fast start”, the residence time of the load at 100% for triggering the load before starting the dimming ramp to the desired value is fixed and equal to 2 seconds.

➤ **4.1.3 Maximum/minimum dimming threshold**

For each generic x channel, the light intensity dimming is limited by two threshold values that can be set using the parameters “**Maximum dimming threshold**” which can have the following values:

- from 55% to **100% (default value)** in steps of 5%

and “**Minimum dimming threshold**” which can have the following values:

- from **0% (default value)** to 50% in steps of 5%

➤ **4.1.4 Brightness reaching with on/off, timed switching, priority command and block commands**

The brightness value determined by activating/deactivating the on/off switching, stairs light, forcing and block of channel x functions can be reached via a ramp or by jumping to the value. This behaviour is determined by the parameter “**Brightness reaching with on/off, timed switching, priority command and block commands**” which can have the following values:

- **with jump to value (default value)**
- with ramp

selecting the value **with ramp**, displays the parameter “**Ramp dimming speed 0% - 100% for on/off, timed switching, priority command and block commands**”; selecting the value **with jump to value**, the dimmer will manage a soft start.

The parameter “**Ramp dimming speed 0% - 100% for on/off, timed switching, priority command and block commands**” is used to set the duration of the dimming from brightness 0% to brightness 100% for the on/off switching, stairs light, forcing and block of channel x functions; the possible values are:

- 1 second
- 2 seconds
- 3 seconds
- **4 seconds (default value)**
- 5 seconds
- 6 seconds
- 7 seconds
- 8 seconds
- 9 seconds
- 10 seconds
- 15 seconds
- 20 seconds
- 25 seconds
- 30 seconds
- 1 minute
- 2 minutes
- 5 minutes
- 10 minutes

➤ **4.1.5 Channel status at bus voltage recovery**

In the case of bus voltage failure, the dimmer maintains the output status.

It is possible to set the status of channel x following bus voltage recovery using the parameter “**Channel status at bus voltage recovery**” which can have the following values:

- sets fixed value
- minimum dimming threshold value
- maximum dimming threshold value
- **as before voltage drop (default value)**

selecting the value **set fixed value** displays the parameter “**Channel brightness at bus voltage recovery**”. The above cited parameter may assume the following values:

- from **0% (default value)** to 100% in steps of 5%

➤ **4.1.6 Channel status at 230V voltage recovery**

At 230V AC voltage failure, channel x will switch to the OFF status (brightness value 0%).

The behaviour of channel x upon recovery of 230V AC voltage, if bus voltage is present at the drop, is determined by this parameter “**Channel status at 230V voltage recovery**” which can have the following values:

- sets fixed value
- minimum dimming threshold value
- maximum dimming threshold value
- as before voltage drop
- **follows last command received** (default value)

by selecting “**as before voltage drop**”, channel x returns to the same conditions that were present at the voltage drop, ignoring all the commands received while network voltage was absent.

If the value “**follows last command received**” is selected, channel x continues processing the commands while the auxiliary voltage is absent, as if the network were present, respecting the relative priorities; when the 230 V voltage is recovered, channel x applies at the output the value determined by the last command that was being executed at that moment.

Selecting **set fixed value** displays the parameter “**Channel brightness at 230V voltage recovery**” and channel x will switch the output to the status set by the parameters, maintaining any other pre-existing condition (block, forcing). The above cited parameter may assume the following values:

- from **0% (default value)** to 100% in steps of 5%

Behaviour at 230V voltage recovery will not be carried out if the power supply failed while an overheating or overload alarm was in progress (the user probably disconnected the power supply to speed up the cooling process or to eliminate the overload).

➤ **4.1.7 Local push button behaviour**

The device has 2 local push-buttons (one per channel); it is possible to define the function of the local push-button associated with channel x with the parameter “**Local push button behaviour**” which can have the following values:

- no effect
the push-button is disabled
- test on/off
each time the push-button is pressed channel x will toggle between ON (100% brightness) and OFF (0% brightness), jumping to the value (soft start hw management). This command has top priority and is executed independently of the active functions, Priority command and Block included.
- **single push button dimmer test** (default value)
In this case, the front push-button acts like a single push-button that, when pressed briefly (0.5 sec), turns on (ON 100%) the output associated with channel x (if it is OFF), and turns it off (OFF) if it is ON (brightness value >0); if pressed for longer, it toggles the controls for brightness increase and decrease (between 0% and 100%) and stops dimming upon release. The dimming speed is fixed at 5 seconds. This command has top priority and is executed independently of the active functions, Priority command and Block included.

Unless it is set at **no effect**, the local push-button controls the output connected to channel x, regardless of the device functions that are active at that moment but without changing the activation status of those functions. This means that if before pressing the local push-button, channel x block/forcing functions were active, they will continue to be active even if the brightness value is changed depending on the type of activation performed on the front push-button.

In the specific case of receiving block/forcing activation commands while the brightness is being regulated by means of a long operation of the front button key (only if **single push button dimmer test**), the associated functions are still activated but the output is always managed by the relative dimming due to the local push-button.

Selecting any value other than **no action** for the parameter **Px “Local push button behaviour”** displays the parameter **Px “Activate/deactivate local button operation from bus”** in order to deactivate and reactivate the operation of the local push-button (defined by the parameter **Px “Local push button behaviour”**) by sending an enabling/disabling command via the new communication object **Ch.x - Local button key function enabling** (Data Point Type 1.003 DPT_Enable). The values that can be set are:

- **disable** (default value)
- enable

selecting enable displays the **communication objects Ch.x - Local button key function enabling** (Data Point Type 1.003 DPT_Enable) and **Ch.x - Local button key function enabling status** (Data Point Type 1.003 DPT_Enable) that permit respectively to receive commands for the activation/deactivation of the function of the local button key and to signal the activation status of the push-button function; the signal is sent upon request, on change and after the bus power supply is restored.

➤ **4.1.8 Overload alarm warning**

For each channel, it is possible to signal an output overload via the communication object **Ch.x - Overload alarm** (Data Point Type 1.005 DPT_Alarm). You can set the conditions that determine the sending of the communication object via the **Overload alarm warning** parameter, which may assume the following values:

- disabled
- on demand only
- **sending on change** (default value)

setting a value other than **disabled**, displays the output communication object **Ch.x - Overload alarm**.

A possible overload is signalled by the red fixed “fault” LED switched on together with the “CHx” LED associated with the channel with the alarm switched on fixed YELLOW.

During the overload situation, the output of the channel with the alarm is switched off and every command received from the bus is ignored.

Any functions that were active at that moment are kept active, but they do not have any influence on the dimmer outputs.

It is possible to try to eliminate the cause of the overload by disconnecting the network voltage and working on the system; to restore normal operation, the network voltage will obviously have to be reconnected. Once the cause of the overload has been eliminated, you can restore normal operation and deactivate the overload signal in the following ways:

- using the front button key of the channel and commanding the output. During an overload, the front button key must be able to command the channel independently of the value of the parameter “Local push button behaviour”. The channel performs a test, switching the output to the maximum brightness value. After approx. 5 seconds, if the overload was eliminated, the corresponding alarm warning on the bus will assume the value FALSE and the channel will switch to the status previous to the overload condition, including the CHx LED.
- During the reset time (approx. 5 seconds) the “CHx” LED flashes YELLOW (frequency 1 Hz 50% On, 50% Off).
- sending a command via bus. Regardless of the command received, the channel performs a test, switching the output to the maximum brightness value. After approx. 5 seconds, if the overload was eliminated, the

corresponding alarm warning on the bus will assume the value FALSE and the channel will follow the last command received; the CHx LED will behave accordingly.
During the reset time (approx. 5 seconds) the “CHx” LED flashes YELLOW (frequency 1 Hz 50% On, 50% Off).

The “Fault” LED, the only one for both channels, deactivates when there are no overload or overheating alarms in progress for either channel.

In the case of a bus voltage failure, the status of the overload alarm must be saved to the non-volatile memory so that if the entire device is switched off while this alarm is active, the condition will be noted immediately when it switches back on.

➤ **4.1.9 230V voltage alarm feedback**

The absence of the 230V AC input voltage can be indicated for each channel (as long as there is bus voltage) via the communication object **Ch.x - 230V voltage alarm** (Data Point Type 1.005 DPT_Alarm). The parameter “**230V voltage alarm feedback**” defines the conditions that determine the sending of the communication object, and can have the following values:

- disabled
- on demand only
- **sending on change** (default value)

setting a value other than **disabled**, displays the output communication object **Ch.x - 230V voltage alarm**. For each channel, in the case of the 230 V voltage absence alarm, the “Load x” LED associated with the channel with the alarm is fixed RED whereas the status of the “CHx” LED and the “Fault” LED is not changed. If you disconnect the input voltage in the case of overheating, the “Fault” LED remains fixed RED, the “CHx” LED is fixed RED and the “Load x” LED is fixed RED.

➤ **4.1.10 Device overheating alarm feedback**

It is possible to signal channel overheating via the communication object **Ch.x - Overheating alarm** (Data Point Type 1.005 DPT_Alarm). You can set the conditions that determine the sending of the communication object via the “**Device overheating alarm feedback**” parameter, which can have the following values:

- disabled
- on demand only
- **sending on change** (default value)

setting a value other than **disabled**, displays the output communication object **Ch.x - Overheating alarm**.

Possible overheating is always signalled by the red fixed “Fault” LED switched on together with the “CHx” LED associated with the channel with the alarm switched on fixed RED.

During overheating, the output associated with the channel with the alarm is fixed and equal to 10% and every command received from the bus is ignored. Any functions that were active at that moment are kept active, but they do not have any influence on the output with the alarm.

There are two ways to try to eliminate the cause of the overheating:

- Waiting for the channel temperature to decrease on its own
- Disconnect the network voltage. In this case, the channel output switches off and a normal operating temperature may be reached faster. To restore normal operation, the network voltage will obviously have to be reconnected

Once the cause of the overheating has been eliminated, you can restore normal operation and deactivate the overheating signal in the following ways:

- using the front button key of the channel and commanding the output. During overheating, the front button key must be able to command the channel independently of the value of the parameter “**Local push button behaviour**”. In particular, if the temperature has gone down below the alarm value, the channel performs a test, switching the output to the maximum brightness value. After approx. 5 seconds, if the

temperature remains below the alarm value, the corresponding alarm signal on the bus will assume the value FALSE and the channel will switch to the status prior to the overheating condition, including "CHx" LEDs. During the reset time (approx. 5 seconds) the "Fault" LED remains on fixed while the "CHx" LED flashes RED (frequency 1 Hz 50% On, 50% Off).

- Sending a command via bus. If the temperature has gone down below the alarm value, the channel, independently of the command received, performs a test, switching the output to the maximum brightness value. After approx. 5 seconds, if the temperature remains below the alarm value, the corresponding alarm warning on the bus will assume the value FALSE and the channel will follow the last command received. During the reset time (approx. 5 seconds) the "Fault" LED remains on fixed while the "CHx" LED flashes RED (frequency 1 Hz 50% On, 50% Off).

The "Fault" LED, the only one for both channels, deactivates when there are no overload or overheating alarms in progress for either channel.

In the case of a bus voltage failure, the status of the overheating alarm must be saved to the non-volatile memory so that if the entire device is switched off while this alarm is active, the condition will be noted immediately when it switches back on.

5 “Channel x switching” menu

Each channel can be switched on/off via the relative **Ch. x - Switching** communication object (Data Point Type: 1.001 DPT_Switch). The communication object is always visible.

This function has the same priority as the stairs light and blinking function; this means that, for each channel, when one of the two functions is activated while the other is already active, it is executed, ending the one that was previously active.

The structure of the menu is as follows:

Fig. 5.1

5.1 Parameters

➤ 5.1.1 Switching on brightness value

When receiving the ON value (1) the dimmer switches channel x to the brightness value set by the parameter “**Switching on brightness value**”, which may assume the following values:

- **last value when ON (memory)** (default value)
(NOTE: in this case, the memory function is active)
- maximum dimming threshold value
- sets fixed value

selecting the value **set fixed value** displays the parameter “**Channel brightness at switch ON**”. The above cited parameter may assume the following values:

- from 5% to **100% (default value)** in steps of 5%

When switched on for the first time, the last ON status value may not be known: the value is initialised with the value “maximum dimming threshold”. The last switching on value to use is always the last brightness value of the channel based on any command, before being switched off. In the case of a bus voltage failure, the value is saved in the non-volatile memory.

When the OFF value (0) is received, the channel always switches to a brightness value of 0 (0%).

The brightness value can be reached in the ON status and the OFF status 0 (0%) via a ramp or by jumping to the value. This behaviour is determined by the parameter “**Brightness reaching with on/off, stairs light, forced positioning, block, blinking, slave**” in the **Channel x settings** menu (see par. 4.1.4).

➤ 5.1.2 Delay at switch ON

It is possible to enable a start (ON) delay time via the parameter “**Delay at switch ON**”; the parameter may have the values:

- **disabled** (default value)
- enabled

If enabled, when receiving an ON command (ON), the jump to “Switching on brightness value” or the start of the dimming ramp are delayed by the value defined by the “**Delay time at switch ON**” parameter; the parameter may have the values:

- **1 s** (default value)
- 2 s
- 3 s
- 5 s
- 10 s
- 15 s
- 20 s
- 30 s
- 45 s
- 1 min
- 1 min 15 s
- 1 min 30 s
- 2 min
- 2 min 30 s
- 3 min
- 5 min
- 15 min
- 20 min
- 30 min
- 1 h
- 2 h
- 3 h
- 5 h
- 12 h
- 24 h

The switching on delay cannot be reset.

Example:

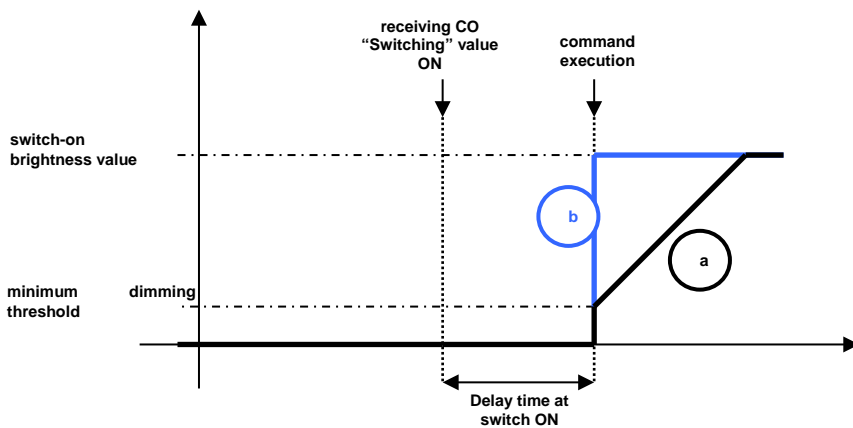

Reaching the brightness value via:

- a) ramp
- b) jump to value

➤ 5.1.3 Delay at switch OFF

In the same manner as the previous parameter, a delay at switch off (OFF) can be enabled via the parameter “**Delay time at switch OFF**”; the parameter may have the values:

- **disabled** (default value)
- single step
- double step

If selecting the **single step** value, when an OFF command is received, the jump to the 0% value or the start of a down ramp are delayed by the value defined by the parameter “**Delay time at switch OFF**”; the parameter may have the values:

- **1 s** (default value)
- 2 s
- 3 s
- 5 s
- 10 s
- 15 s
- 20 s
- 30 s
- 45 s
- 1 min
- 1 min 15 s
- 1 min 30 s
- 2 min
- 2 min 30 s
- 3 min
- 5 min
- 15 min
- 20 min
- 30 min
- 1 h
- 2 h
- 3 h
- 5 h
- 12 h
- 24 h

Example:

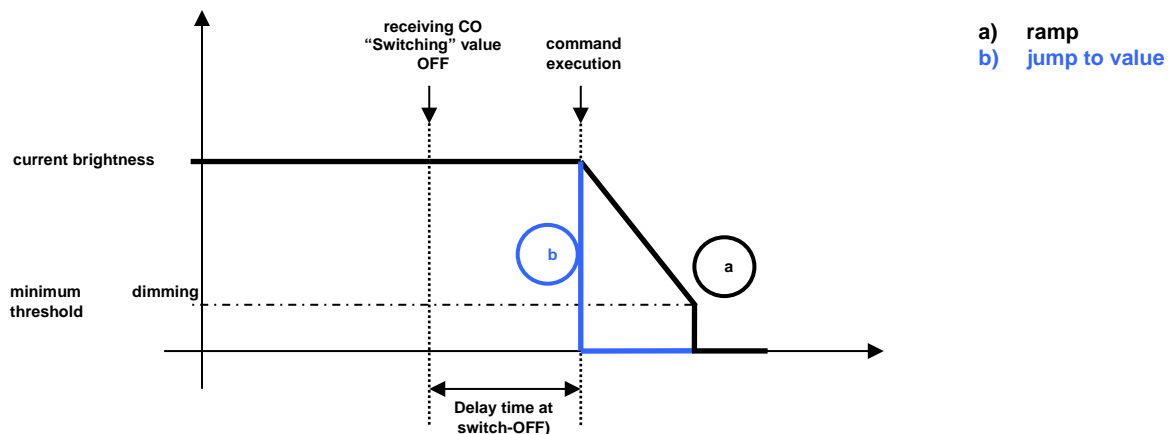

If selecting the **double step** value, the channel switch off phase is divided into two steps. When an off command is received, the jump to value 0% (0) or the start of a down dimming ramp are delayed by 50% of the value defined by the parameter **Px** “**Delay time at switch OFF**”.

When receiving the “OFF” command, if switch off is performed with:

- jump to value, the brightness value is reduced by half (half of the brightness value before receiving the command if greater than the minimum dimming threshold value, otherwise it stops

at the minimum threshold) and kept at this value for the remaining 50% of the time. When the delay has expired, the brightness value is changed to 0% (0).

- Dimming ramp, the dimming ramp is started according to the configured speed in order to reduce the brightness value by half (half of the brightness value before receiving the command if greater than the minimum dimming threshold, otherwise it stops at the minimum threshold); if this value is not reached within half of the switch off delay time, dimming stops in any case and the reached value is kept for the remaining 50% of the time. When the delay has expired, the dimming ramp is started again according to the configured speed until reaching the minimum dimming threshold and then switched off.

Delay at switch off cannot be reset.

Example:

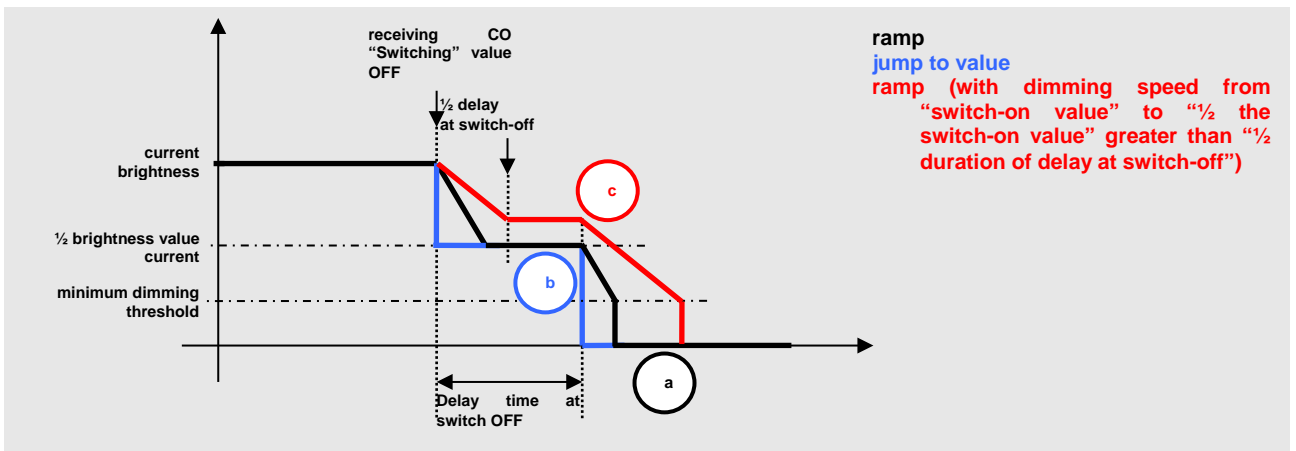

6 “Channel x stairs light” menu

It is possible to enable the timed switching function (stairs light) that automatically switches off the device channel after a period of time after receiving the **Ch. x Timed switching** communication object. This function has the same priority as On/Off switching and blinking; this means that, for each channel, when one of the two functions is activated while the other is already active, it is executed, ending the one that was previously active.

The structure of the menu is as follows:

Main	Stairs light function	<input type="radio"/> deactivated <input checked="" type="radio"/> active
Channel 1 settings	Brightness value during timing	last value when ON (memory) ▼
Channel 1 switching	Activation time [hours]	0 ▲▼
	Activation time [minutes]	1 ▲▼
	Activation time [seconds]	0 ▲▼
Channel 1 stairs light		
Channel 1 relative brightness dimming	Delay on timed activation	<input checked="" type="radio"/> disabled <input type="radio"/> enabled
Channel 1 absolute brightness dimming	Prewarning time	disabled ▼
Channel 1 blinking	Timing stop function	<input checked="" type="radio"/> disabled <input type="radio"/> enabled
Channel 1 logic	Command of activation during timing	restart ▼
Channel 1 scenes	Absolute or relative brightness dimming command during timing	<input type="radio"/> it's executed and cancels timing <input checked="" type="radio"/> it's executed and continues timing
Channel 1 forced positioning	Stairs light activation time setting from bus	<input checked="" type="radio"/> disabled <input type="radio"/> enabled

Fig. 6.1

6.1 Parameters

➤ 6.1.1 Stairs light function

The “**Stairs light function**” parameter is used to activate the function and allow the operating parameters and communication objects to be made visible and configurable. The values that can be set are:

- **deactivated** (default value)
- active

selecting the value **active** displays the parameters and objects relative to that function.

➤ 6.1.2 Brightness value during timing

The parameter “**Brightness value during timing**” is used to set the absolute percentage brightness value that channel x should assume during the period that timing is active; the possible values are:

- **last value when ON (memory)** (default value)
- maximum dimming threshold
- sets fixed value

selecting the value **set fixed value** displays the parameter “**Brightness during timing**”; the parameter may assume the following values:

- from 5% to **100% (default value)** in steps of 5%

When switched on for the first time, the last ON status value may not be known: the value is initialised with the value “maximum dimming threshold”. The last value to use is always the last brightness value of the colour based on any command, before being switched off. In the case of a bus voltage failure, the value is saved in the non-volatile memory.

➤ **6.1.3 Activation time [hours], [minutes], [seconds]**

The “**Activation time [hours]**” parameter is used to define the number of hours for stairs light activation; the values that can be set are:

- from **0 (default value)** to 23, in steps of 1

The “**Activation time [minutes]**” parameter is used to define the number of minutes for stairs light activation; the values that can be set are:

- from 0 to 59 in steps of 1 (**default value 1**)

The parameter “**Activation time [seconds]**” is used to define the number of minutes the stairs light activation time lasts; the values that can be set are:

- from **0 (default value)** to 59, in steps of 1

If the set activation time is 0 hours 0 minutes and 0 seconds, the value is reset to 0 hours 0 minutes and 1 second.

The brightness value can be reached in the ON status and the OFF status (0%) via a ramp or by jumping to the value. This behaviour is determined by the parameter “**Brightness reaching with on/off, stairs light, forced positioning, block, blinking, slave**” in the **Channel x settings** menu (see par. 4.1.4)

➤ **6.1.4 Delay on timed activation**

The parameter “**Delay on timed activation**” is used to define a delay between the moment of receiving the communication object **Ch. x - Timed switching** and the instant in which the command is actually executed (i.e. the moment in which the jump or dimming ramp starts); the values that can be set are:

- **disabled** (default value)
- enabled

selecting the value **enabled** displays the parameter “**Delay on timed activation**” which is used to set the value of the delay itself in seconds. The values that can be set are:

- **1 s** (default value)
- 2 s
- 3 s
- 5 s
- 10 s
- 15 s
- 20 s
- 30 s
- 45 s
- 1 min
- 1 min 15 s
- 1 min 30 s
- 2 min
- 2 min 30 s
- 3 min
- 5 min

- 15 min
- 20 min
- 30 min
- 1 h
- 2 h
- 3 h
- 5 h
- 12 h
- 24 h

Examples:

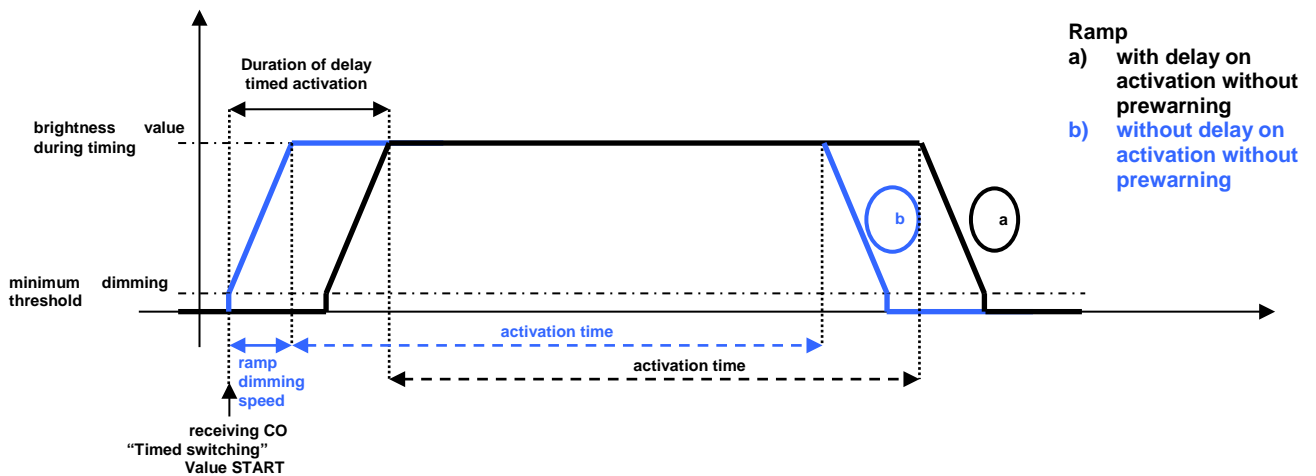
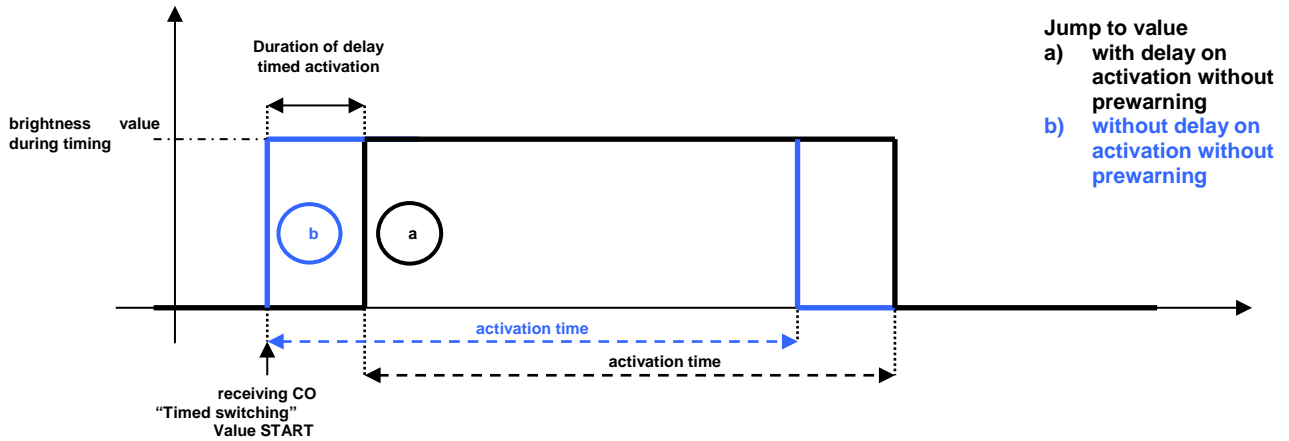

The activation delay cannot be reset.

➤ 6.1.5 Prewarning time

The **Pre-warning time** parameter can be used to enable signalling when the channel will soon be switched off via the automatic reduction of brightness with a dimming ramp between the switching on brightness value to the minimum dimming threshold, for the period of time defined by the prewarning time; the parameter can assume the following values:

- **disabled** (default value)
- 15 s
- 30 s
- 1 min.

Examples:

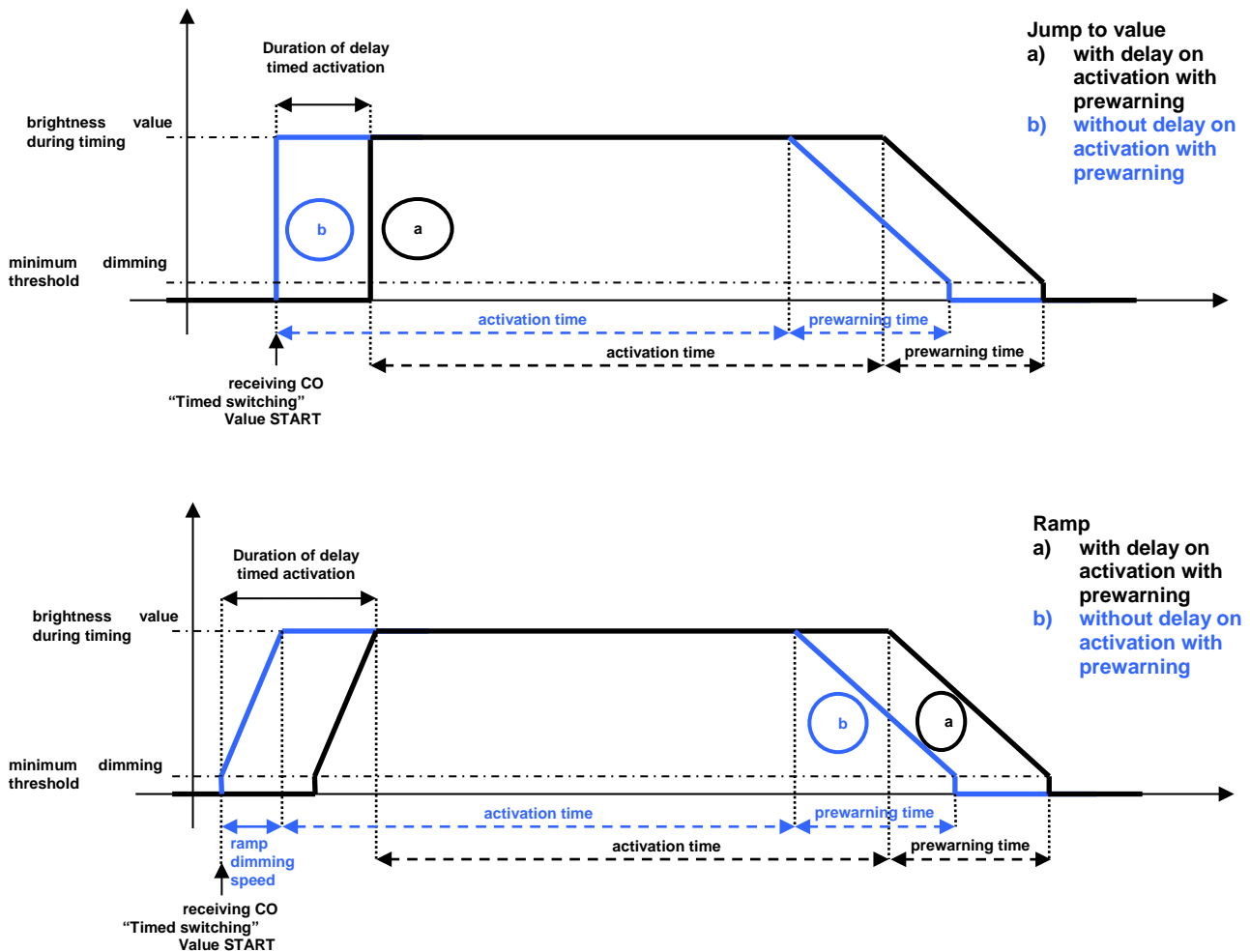

➤ 6.1.6 Timing stop function

The “**Timing stop function**” parameter can be used to enable the possibility of ending the timed activation by receiving the value “0” on the communication object **Ch. x - Timed switching**; the values that can be set are:

- **disabled (default value)**
- enabled

selecting the value **enabled** when receiving the “0” value, the channel will end the timing without any prewarning and deactivate the load according to what is defined by “**Brightness reaching for on/off, stairs light, forced positioning, block, blinking, slave**” in the **Channel x settings** menu (see par. 4.1.4)

➤ 6.1.7 Command of activation during timing

The “**Command of activation during timing**” parameter is used to define the behaviour of the device if a timed activation command is received while timing is already in progress; the values that can be set are:

- no effect
- **restart (default value)**
- extend (multiply by factor)

selecting **extend** displays the “**Multiplicative factor maximum value**” parameter, which can be used to set the maximum number of consecutive activation time extensions. The parameter can have the following values:

- from 2 to **5 (default value)** in steps of 1
-

➤ **6.1.8 Absolute or relative brightness dimming command during timing**

The parameter “**Absolute or relative brightness dimming command during timing**” is used to define channel behaviour when receiving a channel x absolute brightness dimming command and/or a relative brightness dimming command influenced by timing while timing is already in progress; the values that can be set are:

- it's executed and cancels timing
- **it's executed and continues timing** (default value)

selecting the value **it's executed and cancels timing** , the received command is executed and the active timing of channel x is cancelled; selecting the value “**it's executed and continues timing**” assumes that the execution of the command is the continuance of the active timing, without resetting or extending the activation time. In this case, only the brightness value of channel x is changed during timing.

➤ **6.1.9 - Stairs light activation time setting from bus**

The parameter “**Stairs light activation time setting from bus**” displays the input communication object **Ch. x - Stairs light activation time** (Data Point Type: 7.005 DPT_TimePeriodSec), which can be used to receive via bus the activation time value of the stairs light function; the values that can be set are:

- **disabled** (default value)
- enabled

7 “Channel X relative brightness dimming” menu

The relative dimming of the brightness of each channel is performed via the **Ch. x - Brightness dimming** communication object (Data Point Type: 3.007 DPT_Control_Dimming). This object makes it possible to increase or decrease the channel brightness based on the step value and direction coded in the command. Receiving a brightness dimming stop command during the dimming process immediately stops the dimming and maintains the brightness value that was reached. The communication object is always visible.

The structure of the menu is as follows:

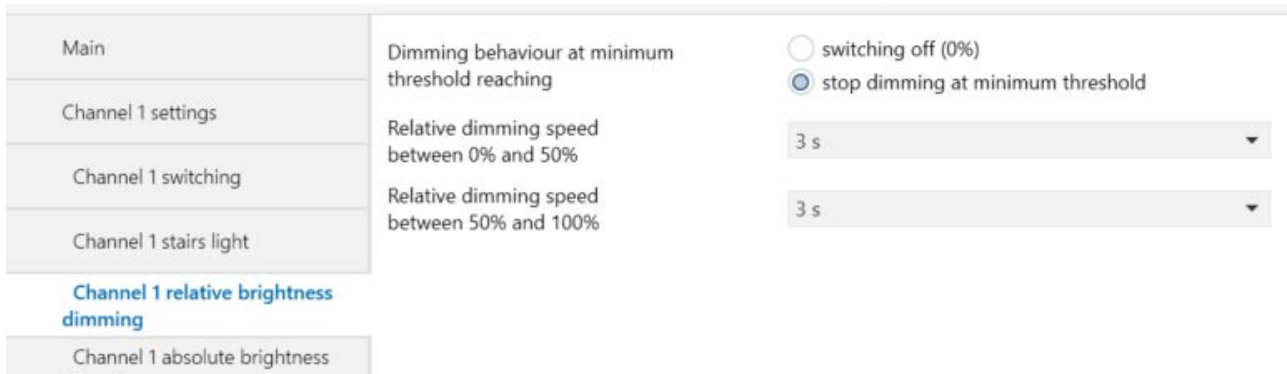

Fig. 7.1

7.1 Parameters

➤ 7.1.1 Dimming behaviour at minimum threshold reaching

Brightness dimming is limited by two threshold values set via the parameters “**Maximum dimming threshold**” and “**Minimum dimming threshold**” in the **Channel x settings** menu (see par. 4.1.3).

The dimming process is normally limited to the set threshold values: this means that if the calculated increasing dimming value exceeds the maximum dimming threshold value, the dimming is stopped and the final brightness value that is set will be the value of the maximum dimming threshold. Similarly, if the calculated decreasing dimming value is lower than the minimum dimming threshold value, the dimming is stopped and the final brightness value that is set will be the value of the minimum dimming threshold. This behaviour can be changed using the parameter “**Dimming behaviour at minimum threshold reaching**” which can have the following values:

- switching off (0%)
- **stop dimming at minimum threshold** (default value)

➤ 7.1.2 Relative dimming speed between 0% and 50% and between 50% and 100%

The dimming speed is determined by 2 time values that define the time interval for switching from 0% to 50% and for switching from 50% to 100%. The two values are defined via the parameters “**Relative dimming speed between 0% and 50%**” and “**Relative dimming speed between 50% and 100%**”. The parameters can assume the following values:

- 1 second
- 2 seconds
- 3 seconds
- **4 seconds** (default value)
- 5 seconds
- 6 seconds
- 7 seconds
- 8 seconds
- 9 seconds

- 10 seconds 10
- 15 seconds 11
- 20 seconds 12
- 25 seconds 13
- 30 seconds 14

Example:

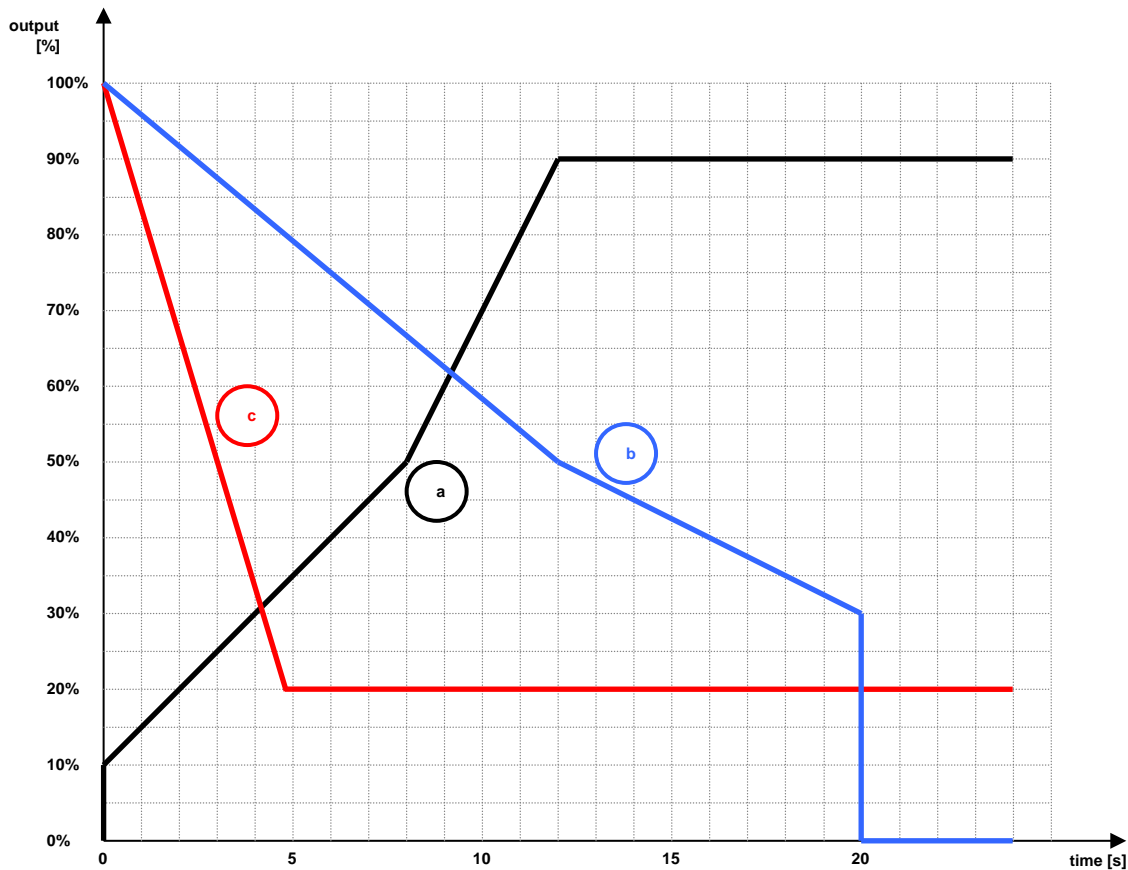

- a) The graph represents the behaviour of the device upon receiving the command “increase to 100%” on CO Ch. x - *Brightness dimming* with initial brightness 0% (off) and with the following settings: **Minimum dimming threshold** → 10%, **Relative dimming speed between 0% and 50%** → 10 s, **Relative dimming speed between 55% and 100%** → 5 s and **Maximum dimming threshold** → 90%.
Reaching the minimum threshold starting from brightness value of 0% is always implemented with jump to value.
- b) The graph represents the behaviour of the device upon receiving the command “decrease to 100%” on CO Ch. x - *Brightness dimming* with initial brightness 100% and with the following settings: **Minimum dimming threshold** → 30%, **Relative dimming speed between 0% and 50%** → 20 s, **Relative dimming speed between 55% and 100%** → 12 s and **Dimming behaviour at minimum threshold reaching** → switching off (0%).
Reaching the value of 0% once the minimum threshold is reached is always implemented with jump to value.
- c) The graph represents the behaviour of the device upon receiving the command “decrease to 100%” on CO Ch. x - *Brightness dimming* with initial brightness 100% and with the following settings: **Minimum dimming threshold** → 20%, **Relative dimming speed between 0% and 50%** → 3 s, **Relative dimming speed between 55% and 100%** → 3 s and **Dimming behaviour at minimum threshold reaching** → stop dimming at minimum threshold.

Reaching the minimum threshold starting from brightness value of 0% is always implemented with a jump.

8 “Channel X absolute brightness dimming” menu

It is possible to set an absolute brightness value for each channel via the communication object **Ch. x - Value command** (Data Point Type: 5.001 DPT_Scaling). The communication object is always visible.

The structure of the menu is as follows:

Fig. 8.1

8.1 Parameters

➤ 8.1.1 Brightness reaching with command value

Starting from the OFF condition, if the brightness value received is lower than the minimum dimming threshold value, the brightness value to be set corresponds to the minimum dimming threshold value. If the brightness value received with the command is higher than the maximum dimming threshold value, the brightness value to set corresponds to the maximum dimming threshold value.

Reaching the brightness value received can be implemented with jump to value or with a ramp. This behaviour is determined by the “**Brightness reaching with command value**” parameter, which can have the following values:

- **with jump to value** (default value)
- with ramp

selecting the value **with jump to value**, the dimmer will manage a soft start hardware. If the value “**with ramp**” is selected, this displays the parameter “**Ramp dimming speed 0% - 100% for command value**”. The parameter can have the following values:

- 1 second
- 2 seconds
- 3 seconds
- **4 seconds** (default value)
- 5 seconds
- 6 seconds
- 7 seconds
- 8 seconds
- 9 seconds
- 10 seconds
- 15 seconds
- 20 seconds
- 25 seconds
- 30 seconds
- 1 minute

- 2 minutes
- 5 minutes
- 10 minutes

➤ **8.1.2 Delay at start with command value**

It is possible to enable a delay at start (changing from OFF to ON with value command >0) via the “**Delay at start with command value**” parameter, which can have the following values:

- **disabled** (default value)
- enabled

by selecting **enabled**, when receiving a command value (with value >0) and with the channel off, the jump to value or the start of the dimming ramp are delayed by the value defined by the new parameter “**Duration of delay at start with command value**” which can have the following values:

- **1 s** (default value)
- 2 s
- 3 s
- 5 s
- 10 s
- 15 s
- 20 s
- 30 s
- 45 s
- 1 min
- 1 min 15 s
- 1 min 30 s
- 2 min
- 2 min 30 s
- 3 min
- 5 min
- 15 min
- 20 min
- 30 min
- 1 h
- 2 h
- 3 h
- 5 h
- 12 h
- 24 h

The delay at start with command value cannot be reset.

➤ **8.1.3 Behaviour with command value < minimum threshold and channel ON**

It is possible to decide if, starting from the condition with the dimmer on, it is permitted to switch off the dimmer (brightness=0%) after receiving an absolute brightness percentage value that is lower than the minimum threshold via this parameter, **Behaviour with command value < minimum threshold and channel ON**”. The parameter can have the following values:

- **switching off (0%)** (default value)
- set minimum threshold value

selecting the value **switching off (0%)** makes it possible to delay the actual switching off with respect to the moment of receiving the absolute brightness dimming communication object via the new parameter “**Delay at switching off with command value < minimum threshold**” which can have the following values:

- **disabled** (default value)
- single step

- double step

by selecting the **single step** value, when a command value is received (with a brightness value lower than the minimum threshold), the jump to value 0% or the start of a down ramp are delayed by the value defined by the parameter “**Duration of delay at switching off with command value < minimum threshold**” parameter, which can have the following values:

- **1 s** (default value)
- 2 s
- 3 s
- 5 s
- 10 s
- 15 s
- 20 s
- 30 s
- 45 s
- 1 min
- 1 min 15 s
- 1 min 30 s
- 2 min
- 2 min 30 s
- 3 min
- 5 min
- 15 min
- 20 min
- 30 min
- 1 h
- 2 h
- 3 h
- 5 h
- 12 h
- 24 h

If selecting the “**double step**” value, the load switching off phase is divided into two steps. When receiving the command value (with a brightness value lower than the minimum threshold), the jump to value 0% or the start of a down dimming ramp are delayed by 50% of the value defined in the Px “**Duration of delay at switching off with command value < minimum threshold**” parameter. The brightness value is changed (jump or ramp) to ½ of the brightness value set upon receiving the command and kept constant for the remaining 50% of the time. When the delay has expired, the brightness value is changed to 0% (jump or ramp).

Example:

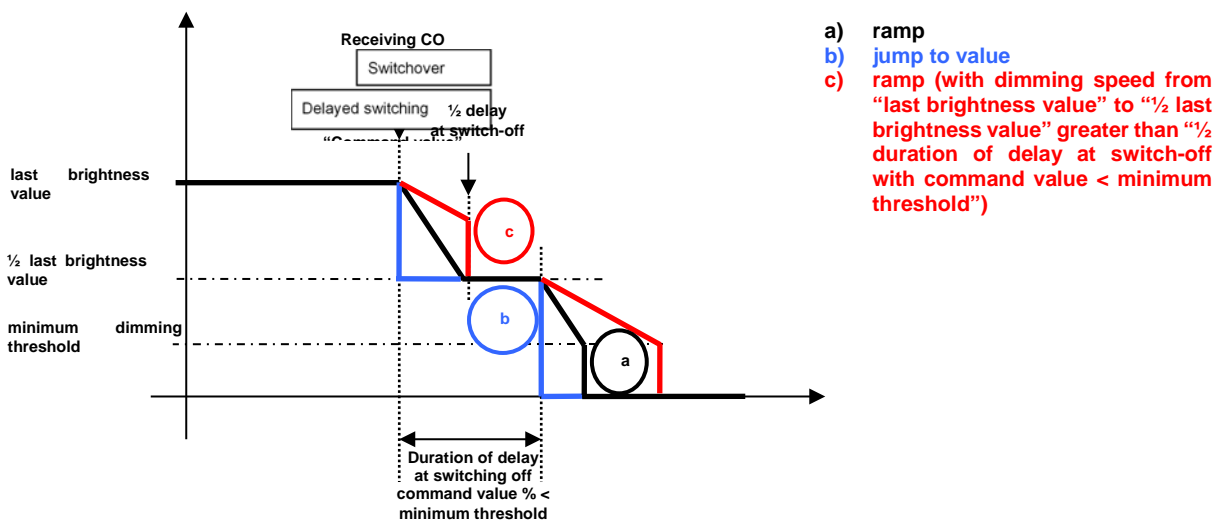

9 “Channel x blinking” menu

One of the output operating modes is the blinking mode, which activates the load for a specific period of time, then deactivates it and repeats the process until the deactivation command is received; from the bus, this operating mode can be controlled via the communication object **Ch.x - Blinking** (Data Point Type: 1.001 DPT_Switch). This function has the same priority as On/Off switching and the stairs light function; this means that, for each channel, when one of the two functions is activated while the other is already active, it is executed, ending the one that was previously active.

The structure of the menu is as follows:

Main	Blinking function	<input type="radio"/> disabled <input checked="" type="radio"/> enabled
Channel 1 settings	Activation value	<input type="radio"/> "0" value <input checked="" type="radio"/> "1" value
Channel 1 switching	Activation time [minutes]	<input type="text" value="0"/>
Channel 1 stairs light	Activation time [seconds]	<input type="text" value="5"/>
Channel 1 relative brightness dimming	Deactivation time [minutes]	<input type="text" value="0"/>
Channel 1 absolute brightness dimming	Deactivation time [seconds]	<input type="text" value="5"/>
Channel 1 blinking		
Channel 1 logic	Brightness channel during activation time	<input checked="" type="radio"/> current brightness <input type="radio"/> customize
Channel 1 scenes	Channel status at blinking mode deactivation	<input checked="" type="radio"/> no change <input type="radio"/> customize
Channel 1 forced positioning	Turn on the blinking mode at bus voltage restore	<input checked="" type="radio"/> no <input type="radio"/> yes
Channel 1 block		

Fig. 9.1

9.1 Parameters

➤ 9.1.1 Blinking function

It is possible to enable the function via the parameter “**Blinking function**” which can have the following values:

- **disabled** (default value)
- enabled

➤ 9.1.2 Activation value

The parameter “**Activation value**” determines which logic value received on the communication object **Ch.x - Blinking** activates the output activation/deactivation process; the values that can be set are:

- “0” value
- “1” value (default value)

➤ 9.1.3 Activation/deactivation time [minutes] / [seconds]

The parameter “**Activation time [minutes]**” is used to set the first of two values (minutes) that make up the output activation time; the values that can be set are:

- from **0 (default value)** to 59, in steps of 1

The parameter "**Activation time [seconds]**" is used to set the last of two values (seconds) that make up the output activation time; the values that can be set are:

- from 0 to 59 in steps of 1 (**default value 5**)

The parameter "**Deactivation time [minutes]**" is used to set the first of two values (minutes) that make up the output deactivation time; the values that can be set are:

- from **0 (default value)** to 59, in steps of 1

The parameter "**Deactivation time [seconds]**" is used to set the last of two values (seconds) that make up the output deactivation time; the values that can be set are:

- from 0 to 59 in steps of 1, (**default value 5**)

➤ **9.1.4 Brightness channel during activation time**

The parameter "**Brightness channel during activation time**" is used to set the brightness the device reproduced using the activation period of the blinking cycle. The values that can be set are:

- **current brightness** (default value)
- customize

selecting the value **current brightness**, the brightness reproduced during the activation period of the flashing cycle is what was set at the moment its activation command was received; if brightness is 0% at the moment the blinking activation command is received, the brightness reproduced is what was active before switching off.

Selecting **customise** displays the parameter "**Percentage value**" which can be used to set the value of the brightness to reproduce during the light sequence activation period; the values that can be set are:

- from 5% to **100% (default value)** in steps of 5%

➤ **9.1.5 Channel status at blinking mode deactivation**

It is possible to define the status of the channel upon receiving the blinking mode deactivation command via the parameter "**Channel status at blinking mode deactivation**" which can have the following values:

- **no change** (default value)
- customize

selecting the value **no change**, the brightness of the channel remains what was set at the moment the blinking deactivation command was received.

Selecting **customise** displays the parameter "**Percentage value**" which can be used to set the value of the brightness to reproduce following the mode deactivation command; the values that can be set are:

- from **0% (default value)** to 100% in steps of 5%

The reaching of the value upon flashing mode deactivation is determined by the value of the parameter "**Brightness reaching for on/off, stairs light, forced positioning, block, blinking, slave**" in the **Channel x settings** menu (see par. 4.1.4).

➤ **9.1.6 Turn on the blinking mode at bus voltage restore**

The parameter “**Turn on the blinking mode at bus voltage restore**” is used to force or not force activation of flashing mode at bus voltage recovery; the values that can be set are:

- **no** **(default value)**
- **yes**

selecting **yes**, if no function with a higher priority than the blinking mode is active, the device will start the blinking phase, ignoring the value set for the “**Channel status at bus voltage recovery**” item in the **Channel x settings** menu; selecting no, the status of the channel and any possible active blinking before voltage drop depend on the setting of the parameter “**Channel status at bus voltage recovery**” in the **Channel x settings** menu.

10 “Channel x Logic” menu

It is possible to subordinate channel x activation/deactivation according to the result of the logic operations, which have dedicated communication objects as inputs.

The structure of the menu is as follows:

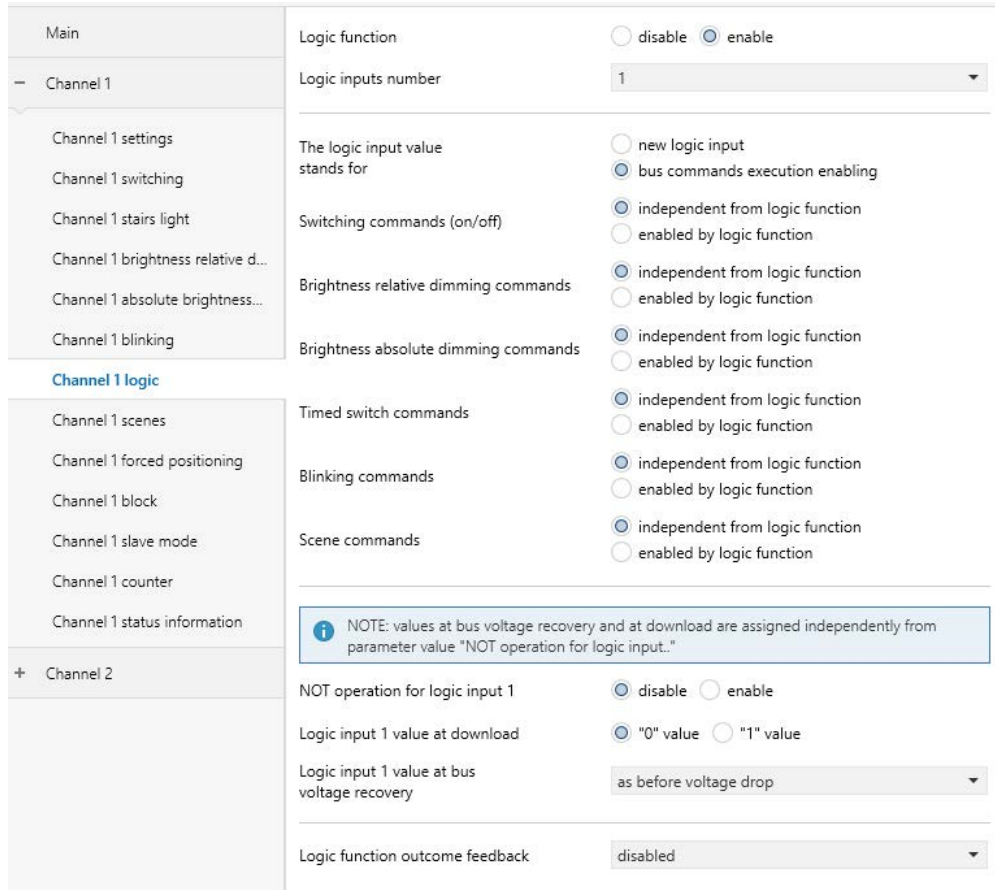

Fig. 10.1

10.1 Parameters

➤ 10.1.1 Logic function

It is possible to enable the logic function via the parameter “**Logic function**” which can assume the following values:

- **deactivated** (default value)
- active

➤ 10.1.2 Logic inputs number

If the function is enabled, it is possible to set the number of logic inputs via the “**Logic inputs number**” parameter, which can assume the following values:

- **1** (default value)
- 2
- 3
- 4
- 5
- 6

- 7
- 8

Depending on the selected value, the parameters “NOT operation for logic input i”, “Logic input i value at download” and “Logic input i value at bus voltage recovery” ($1 \leq i \leq 8$) and the communication objects **Ch. x - Logic input 1**, **Ch. x - Logic input 2**, **Ch. x - Logic input 3**, **Ch. x - Logic input 4**, **Ch. x - Logic input 5**, **Ch. x - Logic input 6**, **Ch. x - Logic input 7** and **Ch. x - Logic input 8** will be displayed (Data Point Type: 1.002 DPT_Bool).

➤ 10.1.3 Operation between logic inputs

If the number of logic inputs set is greater than 1, it is possible to set the logic operation to be executed between the logic inputs. The operation is selected using the “Operation between logic inputs” parameter, which can assume the following values:

- **AND** (default value)
- OR
- NAND
- NOR
- XOR
- XNOR

The outcome of the operations between logic inputs (or the value of the individual logic input, if only one logic input was set) can be used as follows:

- 1 as the input for an additional logic operation that is executed, with the selection of one of the following objects **Ch. x - Switching**, **Ch. x - Timed switching** and **Ch. x - Light sequences i**.

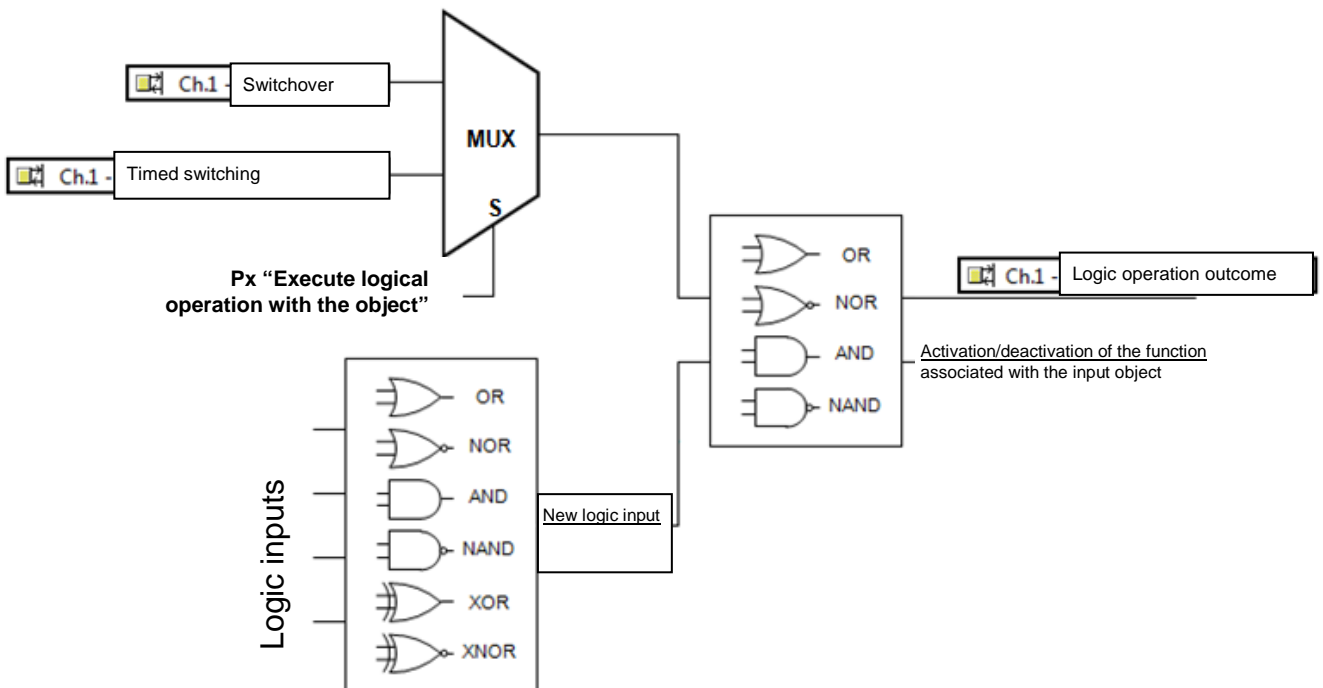

- 2 it can be used to enable the execution of the commands received by the bus on the **Ch. x - Switching**, **Ch. x - Timed switching**, **Ch. x - Brightness dimming**, **Ch. x - Command value**, **Ch. x - Scene** and **Ch. x - Light sequences i** objects.

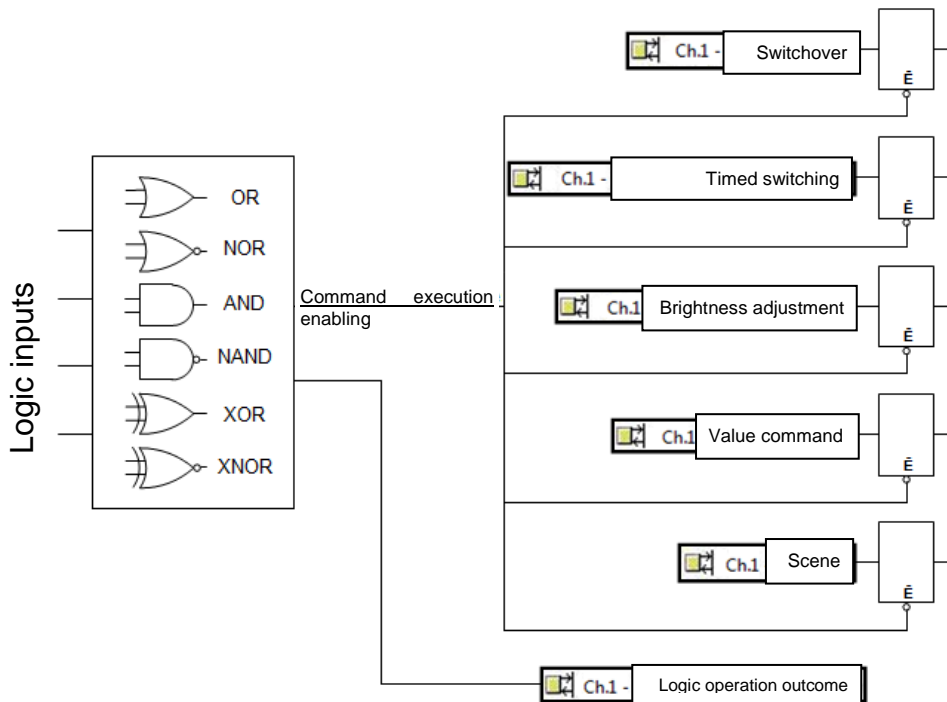

The parameter used to select the function of the outcome of the operation between logic inputs is “**The outcome of the operation between logic inputs stands for**” that, in the case of a single logic input, is replaced by the parameter “**The logic input value stands for**”; these parameters can assume the following values:

- **new logic input** (default value)
- bus commands execution enabling

If the value **new logic input** was selected (case 1), it is possible to define which object should be used to execute the new logic operation via the parameter “**Execute logical operation with the object**” and the logic operation to execute with the selected object via the parameter “**Logical operation to execute**”.

The “**Perform logic operation with the object**” Px (=Execute logical operation with the object)” parameter may assume the following values:

- **switching** (default value)
- timed switching
- blinking

➤ 10.1.4 Logical operation to execute

The “**Logical operation to execute**” parameter may assume the following values:

- **AND** (default value)
- OR
- NAND
- NOR

If the value **bus commands execution enabling** is selected (case 2), a series of parameters appear that are used to set which commands received from the bus require enabling to be executed; the parameters in question are “**Switching commands (on/off)**”, “**Brightness absolute dimming commands**”, “**Brightness relative dimming commands**”, “**Timed switch commands**”, “**Blinking commands**”, “**Scene commands**” and “**Light sequences commands**”; The possible values for these parameters are:

- **independent from logic function** (default value)
- enabled from logic function

The commands enabled by the logic function are only executed if the outcome of the logic operation is true. If the outcome of the logic operation changes from false to true, the commands received after the status change will be executed. The commands received when the outcome of the logic function is false are ignored.

0.1.2 KNX Universal dimming actuator 2 channels 300W > Channel 1 logic

Main	Logic function	<input type="radio"/> deactivated <input checked="" type="radio"/> active
Channel 1 settings	Logic inputs number	1
Channel 1 switching	Operation between logic inputs	AND
Channel 1 stairs light	The logic input value stands for	<input type="radio"/> new logic input <input checked="" type="radio"/> bus commands execution enabling
Channel 1 relative brightness dimming	- Switching commands (on/off)	<input checked="" type="radio"/> independent from logic function <input type="radio"/> enabled by logic function
Channel 1 absolute brightness dimming	- Brightness relative dimming commands	<input checked="" type="radio"/> independent from logic function <input type="radio"/> enabled by logic function
Channel 1 blinking	- Brightness absolute dimming commands	<input checked="" type="radio"/> independent from logic function <input type="radio"/> enabled by logic function
Channel 1 logic		
Channel 1 scenes	- Timed switch commands	<input checked="" type="radio"/> independent from logic function <input type="radio"/> enabled by logic function
Channel 1 forced positioning	- Blinking commands	<input checked="" type="radio"/> independent from logic function <input type="radio"/> enabled by logic function
Channel 1 block	- Scene commands	<input checked="" type="radio"/> independent from logic function <input type="radio"/> enabled by logic function
Channel 1 slave mode	NOT operation for logic input 1	<input checked="" type="radio"/> deactivated <input type="radio"/> active
Channel 1 counter	Logic input 1 value at download	<input checked="" type="radio"/> "0" value <input type="radio"/> "1" value
Channel 1 status Information	Logic input 1 value at bus voltage recovery	as before voltage drop
Channel 2 settings	NOTE: values at bus voltage recovery and at download are assigned independently from param.value "NOT operation for logic input."	
Channel 2 switching		
Channel 2 stairs light	Logic function outcome feedback	disabled
Channel 2 brightness relative		

Fig. 10.2

➤ 10.1.5 NOT operation for logic input N

It is possible to refuse the value received from the bus on the communication objects associated with the logic inputs via the “**NOT operation for logic input 1**”, “**NOT operation for logic input 2**”, “**NOT operation for logic input 3**”, “**NOT operation for logic input 4**”, “**NOT operation for logic input 5**”, “**NOT operation for logic input 6**”, “**NOT operation for logic input 7**” and “**NOT operation for logic input 8**” parameters (displayed or not, depending on the number of enabled logic inputs), which can have the following values:

- **deactivated** (default value)
- active

➤ 10.1.6 Logic input N value at download

It is possible to set the value of the logic inputs at ETS download via the parameters “**Logic input 1 value at download**”, “**Logic input 2 value at download**”, “**Logic input 3 value at download**”, “**Logic input 4 value at download**”, “**Logic input 5 value at download**”, “**Logic input 6 value at download**”, “**Logic input 7 value at download**” and “**Logic input 8 value at download**” (they are displayed depending on the number of enabled logic inputs), which can have the following values:

- “0” value (default value)
- “1” value

➤ 10.1.7 Logic input N value at bus voltage recovery

It is possible to set the value of the logic inputs in the case of bus power supply voltage recovery via the parameters “**Logic input 1 value at bus voltage recovery**”, “**Logic input 2 value at bus voltage recovery**”, “**Logic input 3 value at bus voltage recovery**”, “**Logic input 4 value at bus voltage recovery**”, “**Logic input 5 value at bus voltage recovery**”, “**Logic input 6 value at bus voltage recovery**”, “**Logic input 7 value at bus voltage recovery**” and “**Logic input 8 value at bus voltage recovery**” (they are displayed depending on the number of enabled logic inputs), which can have the following values:

- “0” value
- “1” value
- **as before voltage drop** (default value)

NB: The values at bus voltage recovery and downloading are assigned to logic objects independently of the value of the parameters “**NOT operation for logic input i**” (1<i<8).

➤ 10.1.8 Logic function outcome feedback

Finally, it is possible to enable the sending of the outcome of the logic function on the bus, and specify whether this information should always be sent when an input changes, or only if the outcome of the logic function changes via the “**Logic function outcome feedback**” parameter, which can have the following values:

- **disabled** (default value)
- only if the outcome changes
- even if the outcome does not change

setting a value other than **disabled** displays the **Ch. x - Logic operation outcome**. (Data Point Type: 1.002 DPT_Bool).

The value transmitted on the bus is the result of the operation between the outcome of the logic inputs logic operation and the object selected in the “**Execute logic operation with the object**” parameter, if the “**The outcome of the operation with logic inputs stands for**” parameter assumes the **new logic input** value, or the outcome of the operation between logic inputs if the parameter assumes the **bus command execution enabling** value.

Upon bus voltage recovery, the logic is calculated and the outcome of the operation is transmitted spontaneously on the bus via the relative object **Ch. x - Logic operation outcome**.

11 “Channel x scenes” menu

The scenes function is used to replicate a certain pre-set or previously memorised status upon receipt of the scene execution command.

The structure of the menu is as follows:

Main	Scenes function	<input type="radio"/> disabled <input checked="" type="radio"/> enabled
Channel 1 settings	Scene number 1	unassigned
Channel 1 switching	Brightness starting value for scene 1	100%
Channel 1 stairs light	Scene 1 execution brightness reaching	<input checked="" type="radio"/> with jump to value <input type="radio"/> with ramp
Channel 1 relative brightness dimming	Scene number 2	unassigned
Channel 1 absolute brightness dimming	Brightness starting value for scene 2	100%
Channel 1 blinking	Scene 2 execution brightness reaching	<input checked="" type="radio"/> with jump to value <input type="radio"/> with ramp
Channel 1 logic	Scene number 3	unassigned
Channel 1 scenes	Brightness starting value for scene 3	100%
Channel 1 forced positioning	Scene 3 execution brightness reaching	<input checked="" type="radio"/> with jump to value <input type="radio"/> with ramp
Channel 1 block		

Fig. 11.1

11.1 Parameters

➤ 11.1.1 Scenes function

The “**Scenes function**” parameter is used to activate and configure the function, displaying various function configuration parameters and the relative communication objects.

The scenes function is used to send two possible commands to the device:

- scene execution, which is the command to switch to a determined previously memorised brightness value
- scene learning, which is a command to memorise the current brightness (the moment the command is received).

This function provides 8 scenes, for which the device can store/reproduce 8 different conditions of these functional parameters. The values that can be set are:

- **disabled** (default value)
- enabled

selecting the value **enabled** displays the “**Scene number i**”, “**Brightness starting value for scene i**”, “**Scene i execution brightness reaching**” ($1 \leq i \leq 8$) and “**Scene learning enabling**” parameters and the **Ch. x - Scene** (Data Point Type: 18.001 DPT_SceneControl) communication object via which the scene execution/storage telegrams are received.

➤ 11.1.2 Scene number i

Via the “**Scene number i** ” parameter ($1 \leq i \leq 8$) you can set the numerical value for identifying and therefore executing/memorising the i -th scene; the values that can be set are:

- **unassigned** (default value)
- 0
- ...
- 63

➤ 11.1.3 Brightness starting value for scene i ($1 \leq i \leq 8$)

The parameters “**Brightness starting value for scene i** ” ($1 \leq i \leq 8$) are used to define the initial brightness value that the channel with which the parameter is associated must reach after receiving the telegram for executing the i -th scene; this value must be overwritten following a scene learning command. The possible values are:

- minimum dimming threshold value
- maximum dimming threshold value
- from 0% to **100% (default value)** in steps of 5%

➤ 11.1.4 Scene i execution brightness reaching” ($1 \leq i \leq 8$)

The “**Scene i execution brightness reaching**” parameter ($1 \leq i \leq 8$) determines how the channel or colours reach the brightness value associated with the i -th scene. The parameter may have the following values:

- **with jump to value** (default value)
- with ramp

selecting the value **with jump to value**, the dimmer will manage a soft start hardware. If the value **with ramp**, is selected, this displays the parameter “**Ramp dimming speed 0% - 100% for scene i execution**”; the parameter can have the following values:

- 1 second
- 2 seconds
- 3 seconds
- **4 seconds** (default value)
- 5 seconds
- 6 seconds
- 7 seconds
- 8 seconds
- 9 seconds
- 10 seconds
- 15 seconds
- 20 seconds
- 25 seconds
- 30 seconds
- 1 minute
- 2 minutes
- 5 minutes
- 10 minutes

➤ 11.1.5 Scene learning enabling

The parameter “**Scene learning enabling**” makes it possible to enable/disable the possibility of scene learning via the communication object **Ch. x - Scene**; the parameter can assume the following values:

- disabled
- **enabled** (default value)

If the value **disable** is selected, any scene learning command received from the bus will be ignored and all the scenes will always replicate the initial conditions set in the relative configuration menus; in this case, the format of the communication object **Ch. x - Scene** becomes *17.001 DPT_SceneNumber*.

Selecting the value **enable** displays the **Ch. x - Scene learning enabling**(Data Point Type: 1.003 DPT_Enable) communication object which enables or disables (via bus) the possibility of scene learning via the communication object **Ch. x - Scene**.

12 “Channel x forced positioning” menu

This function is used to enable the channel x priority command or forced positioning function.

The following menu appears in ETS:

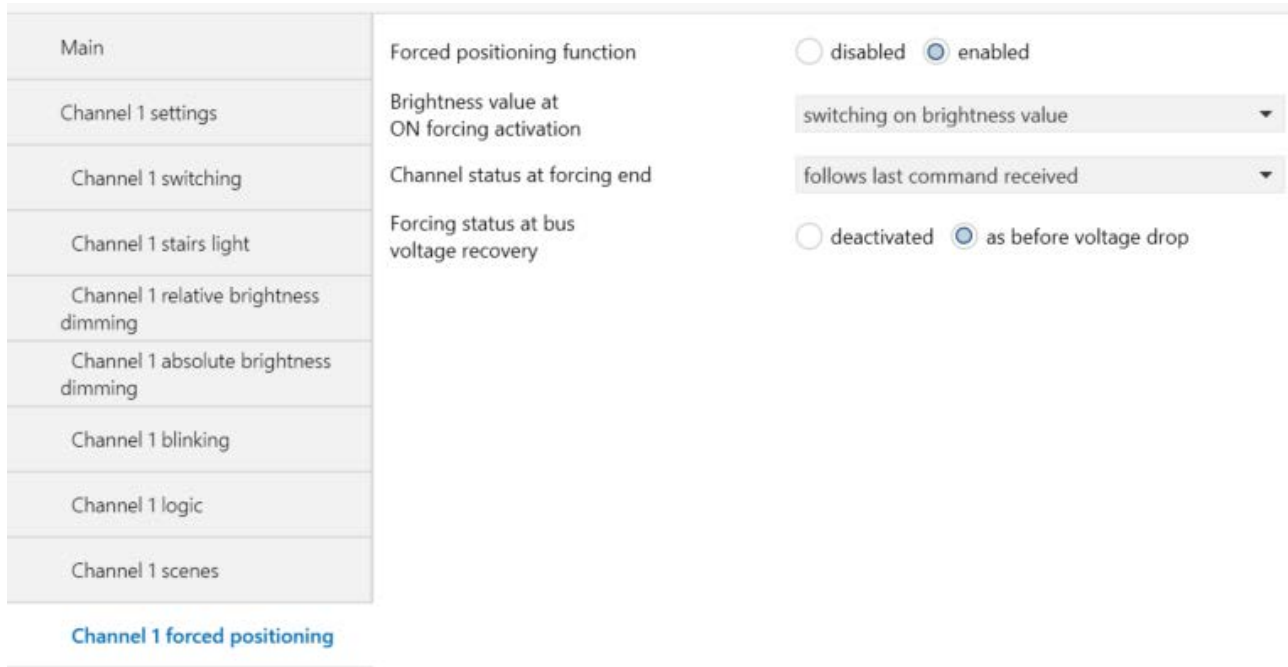

Fig. 12.1

12.1 Parameters

➤ 12.1.1 Forced positioning function

It is possible to enable the function via the “**Forced positioning function**” parameter, which can have the following values:

- **disabled (default value)**
- enabled

If the function is enabled, this displays the **Ch. x - Priority command** (Data Point Type: 2.001 DPT_Switch_Control) and the configuration parameters of the function.

The datapoint coding follows what is shown in the following table:

bit1	bit 0	
0	0	Forced positioning deactivation
0	1	Forced positioning deactivation
1	0	Forced positioning OFF
1	1	Forced positioning ON

➤ 12.1.2 *Brightness value at ON forcing activation*

When receiving a priority command with the ON forcing activation value, channel x switches to the brightness value set via the parameter “**Brightness value at ON forcing activation**” which can have the following values:

- **switching on brightness value (default value)**
- maximum dimming threshold
- sets fixed value

selecting the value **set fixed value** displays the parameter “**Channel brightness at ON forcing activation**”. The parameter can assume the following values:

- from 5% to **100% (default value)** in steps of 5%

When receiving a priority command with the forcing value OFF, the channel will switch to the brightness value of 0%.

The brightness value can be reached in the ON and the OFF (0%) forcing status via a ramp or by jumping to the value. This behaviour is determined by the parameter “**Brightness reaching with on/off, stairs light, forced positioning, block, blinking, slave**” in the **Channel x settings** menu (see par. 4.1.4)

➤ 12.1.3 *Channel status at forcing end*

When receiving a forcing deactivation command, the channel will switch to the brightness value defined by the parameter “**Channel status at forcing end**”; the values that can be set are:

- **follows last command received (default value)**
- status prior to forcing
- no change
- maximum dimming threshold value
- minimum dimming threshold value
- sets fixed value

By selecting the value **follows last command received**, the output follows the dynamics determined by the last command as if the execution of the command was initiated at the moment in which it was effectively received. Essentially, the command is executed in the background and is applied to the channel at the moment forcing is ended. This behaviour applies, for example, to timed actuation commands with timing that has a duration that goes beyond the moment of forcing deactivation or to brightness absolute value dimming commands in which the moment of reaching the set brightness is later than the moment of forcing deactivation. If no telegram is received during the forcing activation period, upon deactivation of the forcing the channel will return to its conditions prior to the activation itself.

Selecting the value **set fixed value** displays the parameter “**Brightness at forcing end**”, which can have the following values:

- from 0% to **100% (default value)** in steps of 5% if the load is monochrome

In the extreme case in which the behaviour **no change** upon forcing deactivation is set and a forcing deactivation command is received while the dimming ramp is in progress for reaching the requested forced value, dimming is stopped and the brightness reached at the moment of receiving the forcing deactivation command is maintained.

The reaching of the value at the end of forced positioning, set via the parameter “**Channel status at forcing end**”, if the selected value is **status prior to forcing/maximum dimming threshold value/minimum dimming threshold value/set fixed value**, is determined by the parameter “**Brightness reaching with on/off, stairs light, forced positioning, block, blinking, slave**” in the **Channel x settings** menu (see par. 4.1.4).

➤ 12.1.4 Forcing status at bus voltage recovery

The “**Forcing status at bus voltage recovery**”) parameter is used to determine the status of the forced positioning function on bus voltage recovery. This parameter is useful if the function is active when the bus voltage drops and you want to have the channel behaviour not be changed after voltage drop. The parameter can assume the following values:

- deactivated
- **as before voltage drop** (default value)

Selecting the value **deactivate** (and forcing was activated before bus voltage drop), when the bus voltage is recovered the forcing function is deactivated and the channel behaves as set in the parameter “**Channel status at forcing end**”. If the value set for this last parameter is **follows last command received**, the channel will execute the last command received before the bus voltage drop that, as a result, must be stored in the non-volatile memory. If the last command received before voltage drop is a timed activation command, when the bus voltage is recovered the command will not be executed and the channel will switch to the OFF status (brightness 0%).

If the value **as before voltage drop** is selected (and forcing was activated before bus voltage drop), when the bus voltage is recovered the forcing function is reactivated and the channel switches to the status determined by the forcing activation command. If a forcing deactivation command is received and the value of the parameter “**Channel status at forcing end**” is **follows last command received**, the channel executes the last command received before the bus voltage drop, which, as a result, must be stored in the non-volatile memory. If the last command received before voltage drop is a timed activation command, when the bus voltage is recovered the command will not be executed and the channel will switch to the OFF status (brightness 0%).

13 “Channel x block” menu

It is possible to block the channel in a certain (settable) condition after receiving the **Ch. x - Block** (Data Point Type: 1.003 DPT_Enable) which activates the block function; until it is deactivated, any command received on all other input communication objects will not be executed. The block function is the function with the highest priority.

Main	Block function	<input type="radio"/> disabled <input checked="" type="radio"/> enabled
Channel 1 settings	Block activation value	<input type="radio"/> "0" value <input checked="" type="radio"/> "1" value
Channel 1 switching	Channel status with active block	maximum dimming threshold value ▼
Channel 1 stairs light	Channel status at block deactivation end	follows last command received ▼
Channel 1 relative brightness dimming	Block on download function	<input checked="" type="radio"/> deactivated <input type="radio"/> active
Channel 1 absolute brightness dimming	Block status at bus voltage recovery	as before voltage drop ▼
Channel 1 blinking		
Channel 1 logic		
Channel 1 scenes		
Channel 1 forced positioning		

[Channel 1 block](#)

Fig. 13.1

13.1 Parameters

➤ 13.1.1 Block function

This function can be enabled via the parameter “**Block function**”, which can assume the following values:

- **disabled** (default value)
- enabled

selecting the **enabled** value displays the communication object **Ch. x - Block** as well as the function configuration parameters.

➤ 13.1.2 Block activation value

The parameter “**Block activation value**” determines which logic value received via the communication object **Ch. x - Block** activates the function; the values that can be set are:

- “0” value
- **“1” value** (default value)

➤ 13.1.3 Channel status with active block

The parameter “**Channel status with active block**” is used to set the status the channel must assume when the block function is activated; the values that can be set are:

- **maximum dimming threshold value** (default value)
- minimum dimming threshold value
- no change
- last switching on value (memory)
- sets fixed value

selecting the value **set fixed value** displays the parameter “**Channel brightness with active block**”. The parameter can assume the following values:

- from 0% to **100% (default value)** in steps of 5%

In the extreme case in which the behaviour **no change** with active block is set and a block activation command is received while the dimming ramp is in progress for reaching the requested value by a function with lower priority than blocking, dimming is stopped and the brightness reached at the moment of receiving the block activation command is maintained.

➤ 13.1.4 Channel status at block deactivation end

The parameter “**Channel status at block deactivation end**” is used to set the status the channel must assume after the block is deactivated; the values that can be set are:

- maximum dimming threshold value
- minimum dimming threshold value
- no change
- last switching on value (memory)
- **follows last command received** (default value)
- as prior to the block activation
- sets fixed value

By selecting the value **follows last command received**, the channel follows the dynamics determined by the last command as if the execution of the command was initiated at the moment in which it was effectively received. Basically, the command is executed in the background and is applied to the output in the moment in which the block is deactivated. This behaviour applies, for example, to timed actuation commands with timing that has a duration that goes beyond the moment of block deactivation or to brightness absolute value dimming commands in which the moment of reaching the set brightness is later than the moment of block deactivation. If no telegram is received during the block activation period, upon deactivation of the block the channel will return to its conditions prior to the activation itself.

Selecting the value **set fixed value** displays the parameter “**Brightness at block end**”. The values that can be set are:

- from 0% to **100% (default value)** in steps of 5%

In the extreme case in which the behaviour **no change** upon block deactivation is set and a block deactivation command is received while the dimming ramp is in progress for reaching the requested forced value with the block active, dimming is stopped and the brightness reached at the moment of receiving the block deactivation command is maintained.

Reaching the brightness value following block activation/deactivation can be reached via a ramp or by a jump to value. This behaviour is determined by the parameter “**Brightness reaching with on/off, stairs light, forced positioning, block, blinking, slave**” in the **Channel x settings** menu (see par. .41.4)

➤ **13.1.5 Block on download function**

The “**Block on download function**” parameter sets the block function status after downloading the application from ETS; the values that can be set are:

- **deactivated** (default value)
- active

➤ **13.1.6 Block status at bus voltage recovery**

The “**Block function at bus voltage recovery**” parameter is used to set the status of the block function after the bus power supply voltage is recovered; the values that can be set are:

- deactivated
- active
- **as before voltage drop** (default value)

Selecting the value **deactivated** (and the block function was activated before bus voltage drop), when the bus voltage is recovered the block function is deactivated and the channel behaves as set in the parameter “**Channel status at block deactivation end**”. If the value set for this last parameter is **follows last command received**, the channel will execute the last command received before the bus voltage drop that, as a result, must be stored in the non-volatile memory. If the last command received before voltage drop is a timed activation command, when the bus voltage is recovered the command will not be executed and the channel will switch to the OFF status (brightness 0%).

If the **as before bus voltage drop** value is selected (and the block function was activated before the bus voltage drop), when the bus voltage is recovered the block function will be reactivated and the channel will switch to the status determined in the “**Channel status with active block**” parameter. If a block deactivation command is received and the value of the parameter “**Channel status at block deactivation end**” is **follows last command received**, the channel executes the last command received before the bus voltage drop, which, as a result, must be stored in the non-volatile memory. If the last command received before voltage drop is a timed activation command, when the bus voltage is recovered the command will not be executed and the channel will switch to the OFF status (brightness 0%).

14 “Channel x slave mode” menu

Channel x can be configured so it can be controlled by a single KNX device as a sensor with constant brightness control in the master-slave configuration; in this configuration, the channel periodically receives, via the communication object **Ch.x - Slave command value** (Data Point Type 5.001 DPT_Scaling) **Ch.x - Slave brightness dimming** (Data Point Type 3.007 DPT_Control_Dimming), brightness percentage dimming values or relative dimming values from the master device, so that it can maintain constant brightness in the environment controlled by the channel.

The structure of the menu is as follows:

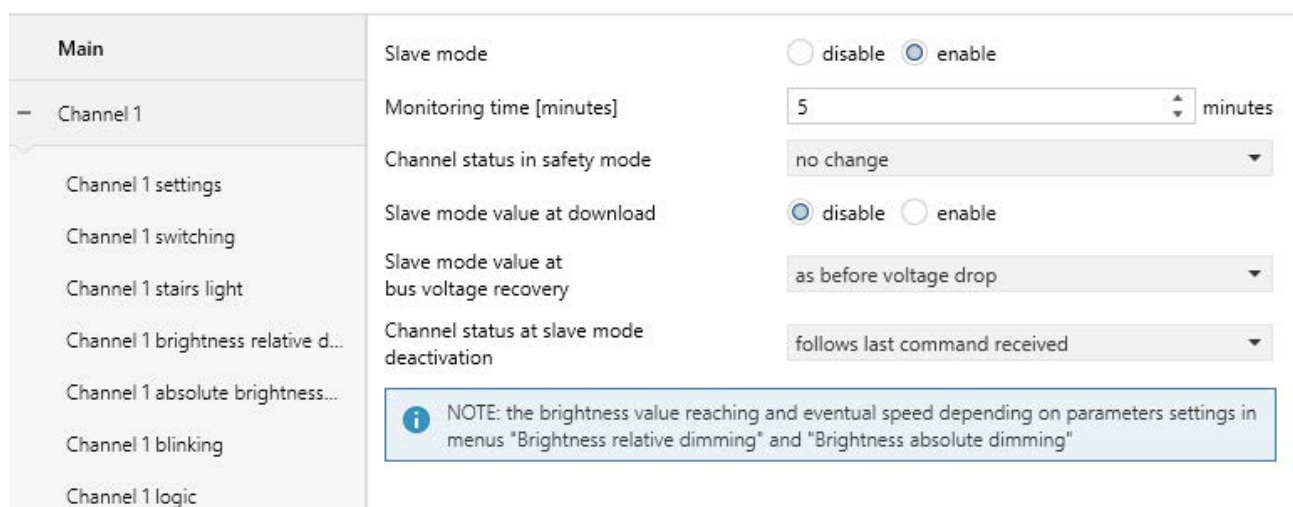

The screenshot shows a configuration interface for 'Channel 1'. On the left is a sidebar menu with options: Channel 1 settings, Channel 1 switching, Channel 1 stairs light, Channel 1 brightness relative d..., Channel 1 absolute brightness..., Channel 1 blinking, and Channel 1 logic. The main area displays the 'Slave mode' configuration. It includes a radio button for 'enable' (selected) and 'disable'. A 'Monitoring time [minutes]' field is set to 5. There are three dropdown menus: 'Channel status in safety mode' (no change), 'Slave mode value at bus voltage recovery' (as before voltage drop), and 'Channel status at slave mode deactivation' (follows last command received). A blue information box at the bottom contains the text: 'NOTE: the brightness value reaching and eventual speed depending on parameters settings in menus "Brightness relative dimming" and "Brightness absolute dimming"'. The 'Main' menu item is also visible at the top left of the interface.

Fig. 14.1

14.1 Parameters

➤ 14.1.1 Slave mode

This function can be enabled via the “**Slave mode**” parameter, which can assume the following values:

- **disabled** (default value)
- enabled

➤ 14.1.2 “Monitoring time [minutes]”;

If the function is enabled, it is possible to set the monitoring time (in seconds) within which channel x waits to receive one of the two possible command objects via the “**Monitoring time [minutes]**” parameter; the parameter can have the following values:

- from 1 to 60 in steps of 1, **5 (default value)**

If a command with a higher priority (block or forcing) is received during slave operation, this interrupts and resets the monitoring time counter; the latter restarts the count from the moment in which the functions with a higher priority are deactivated.

➤ **14.1.3 Channel status in safety mode**

If the dimmer does not receive any command from the master device during the monitoring period, it is possible to set the safety status to which the channel must be brought via this parameter “**Channel status in safety mode**”, which can have the following values:

- maximum dimming threshold value
- minimum dimming threshold value
- **no change** (default value)
- sets fixed value

selecting the value **set fixed value** displays the parameter “**Channel brightness in safety mode**”. The parameter can assume the following values:

- from 0% to **100% (default value)** in steps of 5%

Enabling the function displays the communication objects **Ch.x - Slave command value** and **Ch.x - Slave brightness dimming** to receive brightness dimming commands and the object **Ch.x - Slave mode enabling** (Data Point Type: 1.005 DPT_Enable) which is used to enable/disable the slave function via the bus command.

If the channel mode is slave, any command that is received is ignored (except for the forcing function and block function activation commands) and the dimming thresholds are ignored.

➤ **14.1.4 Slave mode value at download**

The initial value of the function after the ETS download is determined via the parameter “**Slave mode value at download**”. The parameter may have the following values:

- **disabled** (default value)
- enabled

If the **disabled** value is selected, the slave function must be enabled via the communication object **Ch.x - Slave function enabling** (value 1 = enable).

➤ **14.1.5 Slave mode value at bus voltage recovery**

The parameter “**Slave mode value at bus voltage recovery**” is used to determine the value of the function after bus voltage recovery. The parameter may have the following values:

- deactivated
- active
- **as before voltage drop** (default value)

➤ **14.1.6 Channel status at slave mode deactivation**

When the function is deactivated (value 0 = disable the **Ch.x - Slave function enabling** communication object), it is possible to configure the behaviour of the dimmer channel via the “**Channel status at slave mode deactivation**” parameter, which can have the following values:

- maximum dimming threshold value
- minimum dimming threshold value
- no change
- last switching on value (memory)

- **follows last command received** (default value)
- as prior to activation
- sets fixed value

By selecting the value **follows last command received**, the channel follows the dynamics determined by the last command as if the execution of the command was initiated at the moment in which it was effectively received. Essentially, the command is executed in the background and is applied to the output in the moment slave mode is deactivated. This behaviour applies, for example, to timed actuation commands with timing that has a duration that goes beyond the moment of slave mode deactivation or to brightness absolute value dimming commands in which the moment of reaching the set brightness is later than the moment of slave mode deactivation. If no telegram is received during the slave mode activation period, upon deactivation the channel will return to its conditions prior to the activation of the mode itself

Selecting the value **set fixed value** displays the parameter “**Channel brightness at slave mode deactivation**”. The values that can be set are:

- from 0% to **100% (default value)** in steps of 5%

The “**Channel status at slave mode deactivation**” parameter is used to set the value at the end of slave mode. If the selected value is **as prior to activation/maximum dimming threshold value/minimum dimming threshold value/set fixed value/last activation value (memory)**, the reaching of that value is determined by the “**Brightness reaching with on/off, stairs light, forced positioning, block, lamp, slave**” parameter in the **Channel x settings** menu (see par. 4.1.4).

The dimming speed and the behaviour for reaching the brightness value set depend on the settings of the relative parameters present in the menus **Channel x relative brightness dimming** and **Channel x absolute brightness dimming**.

15 “Channel x counter” menu

This is used to enable the counter for the ON or OFF period of the output connected to channel x by setting the counter parameters.

The structure of the menu is as follows:

Main	Counter function	<input type="radio"/> disabled <input checked="" type="radio"/> enabled
Channel 1 settings	Increase the count if	<input type="radio"/> output is OFF (brightness = 0%) <input checked="" type="radio"/> output is ON (brightness > 0%)
Channel 1 switching	Counter value format	2 bytes (hours) ▼
Channel 1 stairs light	Overflow value [hours]	65535 ▲▼
Channel 1 relative brightness dimming	Counter value overflow feedback	<input checked="" type="radio"/> disable <input type="radio"/> enable 1 bit object
Channel 1 absolute brightness dimming	Counter value sending condition	sending on demand only ▼
Channel 1 blinking	Counter reset object	<input checked="" type="radio"/> disable <input type="radio"/> enable
Channel 1 logic		
Channel 1 scenes		
Channel 1 forced positioning		
Channel 1 block		
Channel 1 slave mode		
Channel 1 counter		

Fig. 15.1

15.1 Parameters

➤ 15.1.1 Counter function

This function can be enabled via the parameter “**Counter function**”, which can assume the following values:

- **disabled** (default value)
- enabled

selecting the value **enabled** displays the function configuration parameters.

➤ 15.1.2 Increase the count if

The count is based on the detection of the output status; Two statuses can be detected: Output is ON (brightness > 0%) and output is OFF (brightness = 0%); the “**Increase the count if**” parameter is used to set the status of the output that is considered for increasing the counter. The values that can be set are:

- output is OFF (brightness = 0%)

- **output is ON (brightness > 0%)** (default value)

The count takes place only if bus voltage is present; otherwise, the counter is not increased.

➤ 15.1.3 Counter value format and Overflow value

The counter that is used for the count can have different formats depending on the format selected for transmitting the value on the KNX bus; therefore, with the “**Counter value format**” parameter, it is possible to define the size and code of the communication object used to communicate the counter value. The values that can be set are:

- 2 bytes (seconds)
Maximum countable value: 65535 seconds ≈ 18.2 hours
- 2 byte (minutes)
Maximum countable value: 65535 minutes ≈ 45.5 days
- **2 bytes (hours)** (default value)
Maximum countable value: 65535 hours ≈ 7.4 years

The value set in this item will cause, as a result, the values set for the parameter “**Overflow value**” and the format of the communication object **Ch.x - Count**; the initial value is always 0, regardless of the format selected.

The “**Overflow value**” parameter is used to set the maximum value of the counter; in fact, it is possible to set the maximum count value - i.e. the value beyond which the counter is in an overflow condition. Depending on the value set for the **Counter format** parameter, the values that can be set for this item will be different:

- If the counter format is **2 bytes (seconds)**, this displays the communication object **Ch.x - Count** (Data Point Type: 7.005 DPT_TimePeriodSec) and the values that can be set for the above parameter are:
 - from 1 to **65535 (default value, ≈ 18.2 hours)** in steps of 1
- If the counter format is **2 bytes (minutes)**, this displays the communication object **Ch.x - Count** (Data Point Type: 7.006 DPT_TimePeriodMin) is visible and the values that can be set for the above parameter are:
 - from 1 to **65535 (default value, ≈ 45.5 days)** in steps of 1
- If the counter format is **2 bytes (hours)**, this displays the communication object **Ch.x - Count** (Data Point Type: 7.007 DPT_TimePeriodHrs) is visible and the values that can be set for the above parameter are:
 - from 1 to **65535 (default value, ≈ 7.4 years)** in steps of 1

Once the maximum value has been reached, the counter restarts from 0.

➤ 15.1.4 Counter value overflow feedback

The parameter “**Counter overflow feedback**” is used to enable the display, and therefore the use, of the communication objects that indicate when the differential counter has exceeded its maximum value. The values that can be set are:

- **disable** (default value)
- enable 1 bit object

selecting the value **enable 1 bit object** displays the **Ch.x - Count overflow** (Data Point Type: 1.002 DPT_Bool) communication object by which the device indicates the overflow of the counter; when the overflow occurs, a value of “1” is sent; a value of “0” is never sent.

➤ 15.1.5 Counter value sending condition

The parameter “**Counter sending condition**” is used to define the conditions for sending the current value of the counter; the values that can be set are:

- **sending on demand only** (default value)
- send in case of change
- send periodically
- send in case of change and periodically

Selecting a value other than **send on demand only**, the **Ch.x - Counter sending trigger** communication object is made visible (Data Point Type: 1.017 DPT_Trigger). Selecting the value **send on change** or **send on change and periodically**, displays the parameter “**Minimum counter variation for sending value**” whereas selecting the value **send periodically** or **send on change and periodically** displays the parameter “**Counter sending period**”.

Selecting the value **sending on demand only**, no new parameter will be enabled because the counter value is not sent spontaneously by the device; only in the case of a status read request will it send the user a telegram in response to the command received, giving information about the current value of the counter.

If the differential counter sending condition is different from **on demand only**, there is the possibility to indirectly generate the sending of the current counter value following receipt of a bus telegram on the **Ch.x - counter sending trigger** object (with both a value of “1” and a value of “0”); each time the device receives a telegram on that object, it must immediately send the current value of the counter. After a bus voltage recovery, the value of the counter should be sent in order to update any connected devices.

The parameter “**Minimum counter variation for sending value**”, which is visible if the counter value is sent on change, is used to define the minimum count variation (in relation to the last value sent) that causes the new value to be spontaneously sent; the values that can be set are:

- from 1 to 100 in steps of 1, (default value 10)

The unit of measurement of the minimum variation is the same as that set for the counter format.

The parameter “**Counter sending period [seconds]**”, which is visible if the counter value is sent periodically, is used to define the period with which telegrams indicating the current counter value are spontaneously sent; the values that can be set are:

- from 1 to 255 in steps of 1, (default value 15)

➤ 15.1.6 Counter reset object

The “**Counter reset object**” parameter is used to enable the visualisation, and therefore the use, of the **Ch.x - Counter reset** (Data Point Type: 1.017 DPT_Trigger) communication object, in order to receive, via bus, the counter reset command for resetting the value. The values that can be set are:

- **disable** (default value)
- enable

selecting **enable** displays the **Ch.x - Counter reset** communication object, via which the device receives the counter reset command; if a value “1” or “0” is received, the counter is reinitialised to 0.

In the event of a bus voltage failure, the counter value must be saved in a non-volatile memory and restored when the bus voltage is recovered.

16 “Channel X status information” menu

The **Status information** menu contains the parameters used to set the conditions for sending the channel x status feedback that the device sends via bus telegrams.

The structure of the menu is as follows:

Main	Status information transmission	sending on change
Channel 1 settings	Absolute brightness value transmission	sending on change
Channel 1 switching	- Brightness minimum change for sending value	5%
Channel 1 stairs light	- Minimum interval between successive brightness value feedbacks	1,5 seconds
Channel 1 relative brightness dimming	Status information transmission at bus voltage recovery	<input type="radio"/> disabled <input checked="" type="radio"/> enabled
Channel 1 absolute brightness dimming		
Channel 1 blinking		
Channel 1 logic		
Channel 1 scenes		
Channel 1 forced positioning		
Channel 1 block		
Channel 1 slave mode		
Channel 1 counter		
Channel 1 status Information		

Fig. 16.1

16.1 Parameters

➤ 16.1.1 Status information transmission

The device signals the status of the load connected to the channel x connected to it via the communication object **Ch. x - Status** (Data Point Type 1.001 DPT_Switch); the communication object assumes the value 1 = ON when the absolute dimming percentage value >0, and the value 0 = OFF when the percentage dimming value is = 0. It is possible to set the conditions that determine the sending via the “**Status information transmission**” parameter, which can have the following values:

- disabled
- on demand only
- **sending on change** (default value)

Selecting a value other than **disabled** displays the communication object **Ch. x - Status**. Selecting the value **sending on change**, the communication object is sent spontaneously when the status switches from ON to

OFF and vice versa. This means that if the brightness dimming is changed, staying higher than 0 ("ON" status), the communication object does not need to be retransmitted on the bus.

➤ 16.1.2 Absolute brightness value transmission

The device signals the current brightness percentage value of channel x via the communication object **Ch. x - Brightness value** (Data Point Type 5.001 DPT_Scaling); it is possible to set the conditions that determine the sending of the brightness value feedback communication object using the parameter "**Absolute brightness value transmission**", which can have the following values:

- disabled
- on demand only
- **sending on change** (default value)

selecting a value other than **disabled** displays the communication object **Ch. x - Brightness value**. Selecting the value **sending on change** displays the "**Brightness minimum change for sending value**" and "**Minimum interval between successive brightness value feedbacks**" parameters.

The "**Brightness minimum change for sending value**" parameter is used to set the value of the minimum change necessary for triggering the sending of the communication object dedicated to the brightness value. The parameter can have the following values:

- 1%
- 2%
- **5%** (default value)
- 10%
- 15%
- 25%

If the channel x brightness value feedback takes place "on change", it may occur during a dimming ramp that the brightness values change quickly and the device is not able to send all feedback correctly. To avoid this problem, a minimum time interval can be defined between sending one brightness value and the next one via the "**Minimum interval between successive brightness value feedbacks**" parameter, which is only assessed if there was a change in brightness that exceeds the minimum value set via the "**Brightness minimum change for sending value**" parameter.

The "**Minimum interval between successive brightness value feedbacks**" parameter can assume the following values:

- 500 ms
- 1 second
- **1.5 seconds** (default value)
- 2 seconds

➤ 16.1.3 Status information transmission at bus voltage recovery

Via the parameter "**Status information transmission at bus voltage recovery**" it is possible to determine if the communication objects "Status", "Brightness value", configured for being sent upon change, must also be sent at bus voltage recovery. The parameter can have the following values:

- disabled
- **enabled** (default value)

17 Behaviour in the case of bus/230V voltage drop/recovery - front button keys - function priority

The behaviour of the dimmer in the case of 230V network voltage or bus power supply drop or recovery, the management of the front button key associated with channel x and the execution priority of the various functions in the case contemporaneity is summarised below.

17.1 Behaviour in the case of bus voltage drop and recovery

In the case of bus voltage failure, the dimmer maintains the output status.

It is possible to set the status the channel must assume following the recovery of the bus voltage via the parameter “**Channel status at bus voltage recovery**” in the **Channel x settings** menu (see par. 4.1.5).

At bus voltage recovery, they are evaluated in order of priority for each channel:

- 1 “Block object value at bus voltage recovery” - if the block is not active
- 2 “Forcing status at bus voltage recovery” - if forcing is not active
- 3 “Channel status at bus voltage recovery” - (see Priority paragraph)

17.2 Behaviour in the case of 230V voltage drop and recovery

At the 230V voltage failure, each channel will switch to the OFF status (brightness value 0%). If the bus voltage is present, a signal is transmitted on the bus via the communication object **Ch.x - Auxiliary voltage absence alarm**.

The behaviour upon return of the 230V voltage is determined by the parameter “**Channel status at 230V voltage recovery**” in the **Channel x settings** menu (see par. 4.1.6)

17.3 Front button key operation

The function of the front button key on the device associated with channel x is determined by the parameter “**Local push button behaviour**” in the **Channel x settings** menu (see par. 4.1.7)

17.4 Priority of the functions

The priority of the functions is shown in the following table:

Function	Priorities	
Relative brightness dimming	1	low
On/off switching	1	
Timed switching	1	
Absolute brightness dimming	1	
Scenes	1	
Brightness sequences	1	
Logic function (if used for enabling of commands)	2	
Channel status at forcing end	3	
Channel status at block deactivation end	4	
Channel status at bus voltage recovery	5	
Blinking mode on bus voltage recovery	6	
Slave mode value at bus voltage recovery	7	
Forcing status at bus voltage recovery	8	
Block function at bus voltage recovery	9	
Slave mode	10	
Forcing	11	

Block	12	
Front button key	13	
Channel status after 230V voltage recovery with bus voltage present	14	
Status upon 230V voltage failure with bus voltage present (OFF)	15	
Status at bus voltage drop	16	
Overload alarm	17	
Overheating alarm	18	high

To sum up, in normal operating conditions the device behaves as follows:

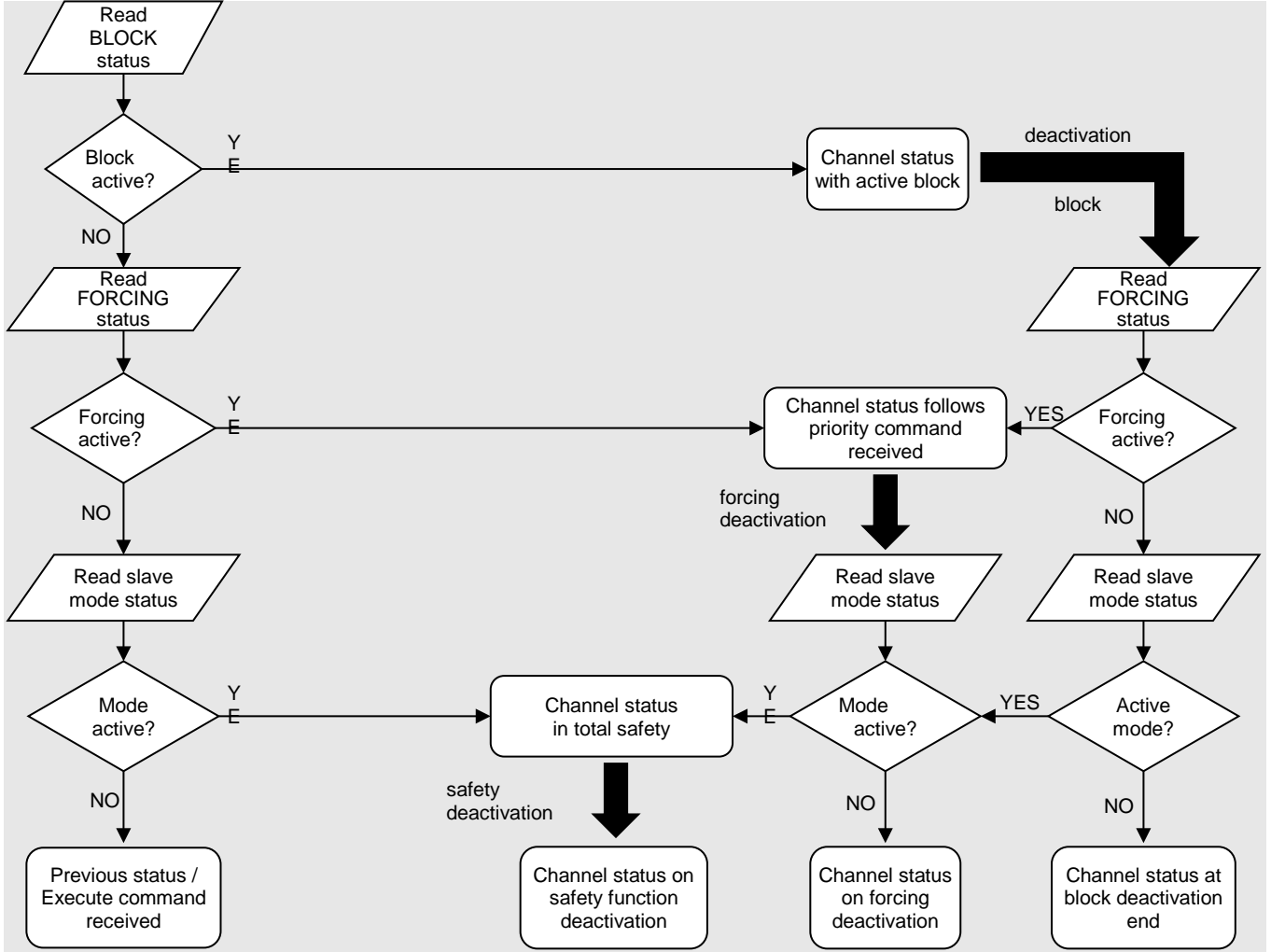

Fig. 17.1

When the bus voltage is recovered, the device behaves as shown in the following flow diagram:

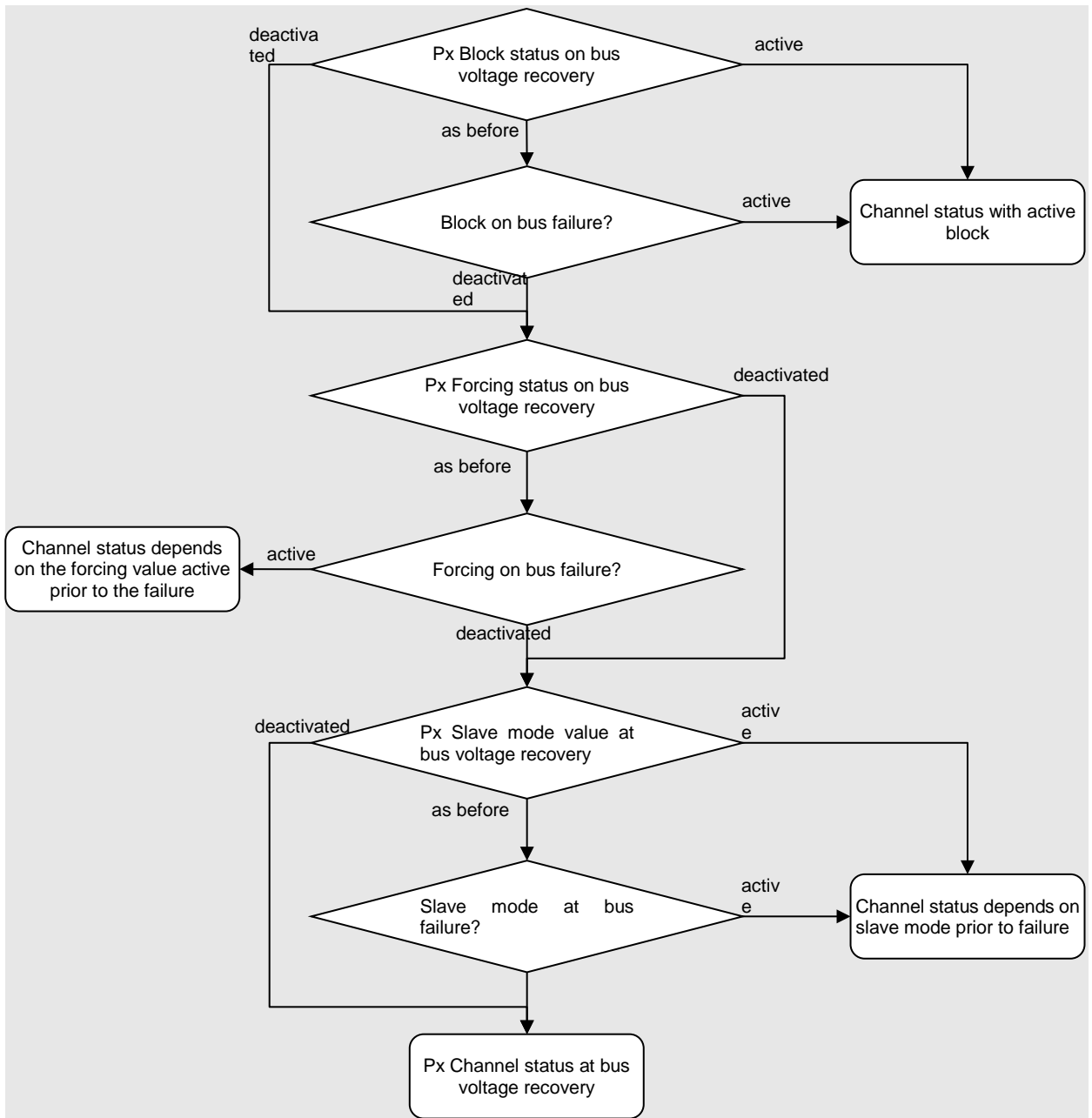

Fig. 17.2

18 Alarm signalling

For each channel, it is possible to signal an output overload via the communication object **Ch.x - Overload alarm** (Data Point Type 1.005 DPT_Alarm). It is possible to set the conditions that determine the sending of the communication object via the parameter “**Overload alarm warning**” in the Channel x settings menu (see par. 4.1.8).

A possible overload is signalled by the red fixed “fault” LED switched on together with the “CHx” LED associated with the channel with the alarm switched on fixed YELLOW.

During the overload situation, the output of the channel with the alarm is switched off and every command received from the bus is ignored.

Any functions that were active at that moment are kept active, but they do not have any influence on the dimmer outputs.

It is possible to try to eliminate the cause of the overload by disconnecting the network voltage and working on the system; to restore normal operation, the network voltage will obviously have to be reconnected. Once the cause of the overload has been eliminated, you can restore normal operation and deactivate the overload signal in the following ways:

- using the front button key of the channel and commanding the output. During an overload, the front button key must be able to command the channel independently of the value of the parameter “Local push button behaviour”. The channel performs a test, switching the output to the maximum brightness value. After approx. 15 seconds, if the overload was eliminated, the corresponding alarm warning on the bus will assume the value FALSE and the channel will switch to the status previous to the overload condition, including the CHx LED.
During the reset time (approx. 15 seconds) the “CHx” LED flashes YELLOW (frequency 1 Hz 50% On, 50% Off).
- sending a command via bus. Regardless of the command received, the channel performs a test, switching the output to the maximum brightness value. After approx. 15 seconds, if the overload was eliminated, the corresponding alarm warning on the bus will assume the value FALSE and the channel will follow the last command received; the CHx LED will behave accordingly.
During the reset time (approx. 15 seconds) the “CHx” LED flashes YELLOW (frequency 1 Hz 50% On, 50% Off).

The “Fault” LED, the only one for both channels, deactivates when there are no overload or overheating alarms in progress for either channel.

In the case of a bus voltage failure, the status of the overload alarm must be saved to the non-volatile memory so that if the entire device is switched off while this alarm is active, the condition will be noted immediately when it switches back on.

The absence of the 230V AC input voltage can be indicated for each channel (as long as there is bus voltage) via the communication object **Ch.x - 230V voltage alarm** (Data Point Type 1.005 DPT_Alarm). It is possible to set the conditions that determine the sending of the communication objects via the parameter “**230V voltage alarm feedback**” in the Channel x settings menu (see par. 4.1.9).

For each channel, in the case of the 230 V voltage absence alarm, the “Load x” LED associated with the channel with the alarm is fixed RED whereas the status of the “CHx” LED and the “Fault” LED is not changed. If you disconnect the input voltage in the case of overheating, the “Fault” LED remains fixed RED, the “CHx” LED is fixed RED and the “Load x” LED is fixed RED.

Similarly, if you disconnect the input voltage in the case of an overload, the “Fault” LED remains fixed RED, the “CHx” LED is fixed YELLOW and the “Load x” LED is fixed RED.

It is possible to signal channel overheating via the communication object **Ch.x - Overheating alarm** (Data Point Type 1.005 DPT_Alarm). It is possible to set the conditions that determine the sending of the communication object via the parameter “**Overheating alarm warning**” in the Channel x settings menu (see par. 4.1.10).

Possible overheating is always signalled by the red fixed “Fault” LED switched on together with the “CHx” LED associated with the channel with the alarm switched on fixed RED.

During overheating, the output associated with the channel with the alarm is fixed and equal to 10% and every command received from the bus is ignored. Any functions that were active at that moment are kept active, but they do not have any influence on the output with the alarm.

There are two ways to try to eliminate the cause of the overheating:

- Waiting for the channel temperature to decrease on its own
- Disconnect the network voltage. In this case, the channel output switches off and a normal operating temperature may be reached faster. To restore normal operation, the network voltage will obviously have to be reconnected

Once the cause of the overheating has been eliminated, you can restore normal operation and deactivate the overheating signal in the following ways:

- using the front button key of the channel and commanding the output. During overheating, the front button key must be able to command the channel independently of the value of the parameter **”Local push button behaviour”**. In particular, if the temperature has gone down below the alarm value, the channel performs a test, switching the output to the maximum brightness value. After approx. 15 seconds, if the temperature remains below the alarm value, the corresponding alarm signal on the bus will assume the value FALSE and the channel will switch to the status prior to the overheating condition, including “CHx” LEDs. During the reset time (approx. 15 seconds) the “Fault” LED remains on fixed while the “CHx” LED flashes RED (frequency 1 Hz 50% On, 50% Off).
- Sending a command via bus. If the temperature has gone down below the alarm value, the channel, independently of the command received, performs a test, switching the output to the maximum brightness value. After approx. 15 seconds, if the temperature remains below the alarm value, the corresponding alarm warning on the bus will assume the value FALSE and the channel will follow the last command received. During the reset time (approx. 15 seconds) the “Fault” LED remains on fixed while the “CHx” LED flashes RED (frequency 1 Hz 50% On, 50% Off).

The “Fault” LED, the only one for both channels, deactivates when there are no overload or overheating alarms in progress for either channel.

In the case of a bus voltage failure, the status of the overheating alarm must be saved to the non-volatile memory so that if the entire device is switched off while this alarm is active, the condition will be noted immediately when it switches back on.

The behaviour of the device LEDs in the case of an alarm is:

Event	“Fault” LED	“CHx” LED	“Load x” LED
Voltage absence	-	-	fixed red
Overload in progress	fixed red	fixed yellow	-
Reset after overload	fixed red	flashing yellow (1 Hz)	-
Overheating in progress	fixed red	fixed red	-
Reset after overheating	fixed red	flashing red (1 Hz)	-

19 Factory reset / signalling of ETS download in progress / application deleted

The device can be used to perform a factory reset via the following procedure:

1. Disconnect the power (KNX terminal)
2. Press the KNX address programming key
3. Reconnect the power supply (KNX terminal) with the programming key still pressed
4. After approx. 5 seconds, 5 fast flashes of the programming LED to signal that the factory reset was performed

After a factory reset, all the factory parameters are reset along with the physical factory address, and the FDSK (Factory Default Setup Key - do masterreset) is reactivated.

Attention! If an application is downloaded from ETS with KNX Secure enabled, it will not be possible to download another from a different ETS project before performing the factory reset from the local menu. The procedure for resetting the FDSK is essential and therefore it is not enough to delete the application on the device via ETS.

During the download of the ETS application, the red physical address programming LED blinks cyclically approx. every 1.5 seconds. The LED is deactivated at the end of the download.

Following the “delete application” command performed via ETS, the device performs a factory reset (see above), maintaining the physical address (unless the command “delete application and physical address” is performed).

20 Communication objects

By enabling all the functions available, all the associated communication objects will be made visible.

The following tables summarise all the communication objects with their specific ID numbers, names and functions displayed in ETS, plus a short description of the function and the type of Datapoint used.

Communication objects with input functions

The following table contains all the objects with an input function.

#		Object name	Function of object	Description	Datapoint type
Ch 1	Ch 2				
1	34	Ch. x - Switching	On/Off	Channel x ON/OFF switching	1.001 DPT_Switch
2	35	Ch. x - Brightness dimming	Increase/decrease	Channel X brightness relative dimming	3.007 DPT_Control_Dimming
3	36	Ch. x - Value command	% value	Set channel x absolute brightness value (value %)	5.001 DPT_Scaling
4	37	Ch. x - Timed switching	Start/Stop	Channel x stairs light timed command	1.010 DPT_Start
5	38	Ch.x - Blinking	Activate/Deactivate	Receives the activation/deactivation commands for load blinking mode	1.001 DPT_Switch
6	39	Ch. x - Scenes	Execute/Store	Allows the storage/execution of channel x scenes	18.001 DPT_SceneControl
7	40	Ch. x - Priority command	On/Off forced positioning	Forces the output value of channel x to a certain status	2.001 DPT_Switch_Control
8	41	Ch. x - Block	Activate/Deactivate	Blocks the status of channel x in a status that can be parametrised	1.003 DPT_Enable communication objects
9	42	Ch.x - Logic input 1	Logic	Logic function input	1.002 DPT_Bool
10	43	Ch.x - Logic input 2	Logic	Logic function input	1.002 DPT_Bool
11	44	Ch.x - Logic input 3	Logic	Logic function input	1.002 DPT_Bool
12	45	Ch.x - Logic input 4	Logic	Logic function input	1.002 DPT_Bool
13	46	Ch.x - Logic input 5	Logic	Logic function input	1.002 DPT_Bool
14	47	Ch.x - Logic input 6	Logic	Logic function input	1.002 DPT_Bool
15	48	Ch.x - Logic input 7	Logic	Logic function input	1.002 DPT_Bool
16	49	Ch.x - Logic input 8	Logic	Logic function input	1.002 DPT_Bool
20	53	Ch. x - Stairs light activation time	Value in seconds	Channel x stairs light timing value	7.005 DPT_TimePeriodSec
21	54	Ch. x - Scene learning enabling	Enable/disable	Enables/disables channel x scene learning	1.003 DPT_Enable communication objects
22	55	Ch. x - Slave mode enabling	Enable/disable	Enable/disable slave mode	1.003 DPT_Enable communication objects
23	56	Ch. x - Slave brightness dimming	Increase/decrease	Channel relative brightness dimming in slave mode	3.007 DPT_Control_Dimming
24	57	Ch. x - Slave value command	% value	Set channel x absolute brightness value (value %) in slave mode	5.001 DPT_Scaling
27	60	Ch.x - Counter sending trigger	Counter value transmission	Receives the request (trigger) to send the current value of the counter	1.017 DPT_Trigger

28	61	Ch.x - Counter reset	Resets the value	Receives the counter value reset command	1.017 DPT_Trigger
32	65	Ch.x - Local button key function enabling	Enable/disable	Enable/disable the function of the local push-button	1.003 DPT_Enable communication objects

Communication objects with output functions

The following table contains all the objects with an output function.

#		Object name	Function of object	Description	Datapoint type
Ch 1	Ch 2				
17	50	Ch. x - Status	On/Off	Channel x on/off status	1.001 DPT_Switch
18	51	Ch. x - Brightness value	% value	Channel x current brightness value	5.001 DPT_Scaling
19	52	Ch. x - Logic operation outcome	Logic	Channel x logic function output	1.002 DPT_Bool
25	58	Ch.x - Count	Value 0 .. 65535 [s]	Sends the counter value (expressed in seconds)	7.005 DPT_TimePeriodSec
25	58	Ch.x - Count	Value 0 .. 65535 [min]	Sends the counter value (expressed in minutes)	7.006 DPT_TimePeriodMin
25	58	Ch.x - Count	Value 0 .. 65535 [h]	Sends the counter value (expressed in hours)	7.007 DPT_TimePeriodHrs
26	59	Ch.x - Count overflow	Overflow status	Sends the counter overflow signal	1.002 DPT_Bool
29	62	Ch.x - 230V voltage alarm	True/false	230V input voltage below threshold feedback	1.005 DPT_Alarm
30	63	Ch.x - Overload alarm	True/false	Output overload warning	1.005 DPT_Alarm
31	64	Ch.x - Overheating alarm	True/false	Channel overheating warning	1.005 DPT_Alarm
33	66	Ch.x - Local button key function enabling status	Enabled/disabled	Sends the local button key function enabling status	1.003 DPT_Enable communication objects

Punto di contatto indicato in adempimento ai fini delle direttive e regolamenti UE applicabili:
Contact details according to the relevant European Directives and Regulations:
GEWISS S.p.A. Via D.Bosatelli, 1 IT-24069 Cenate Sotto (BG) Italy tel: +39 035 946 111 E-mail: qualitymarks@gewiss.com

According to applicable UK regulations, the company responsible for placing the goods in UK market is:
GEWISS UK LTD - Unity House, Compass Point Business Park, 9 Stocks Bridge Way, ST IVES
Cambridgeshire, PE27 5JL, United Kingdom tel: +44 1954 712757 E-mail: gewiss-uk@gewiss.com



+39 035 946 111
8:30 - 12:30 / 14:00 - 18:00
lunedì - venerdì / monday - friday



www.gewiss.com

