

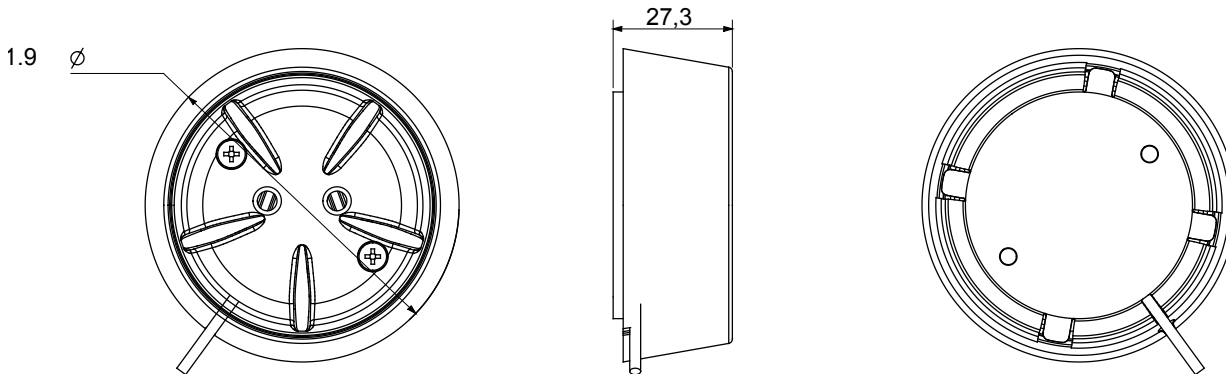

Surface mounting accessory for a GWA connected water sensor1514.

Category	Accessory for flood sensor surface mounting	Colour	White
Material	Technopolymer	Standard	2014/53/EU
IP degree	IP20	Working temperature	0 ÷ +50 °C
Stocking temperature	-20 ÷ +80 °C	Relative humidity (non-condensative)	10 ÷ 95%
Support dimension (mm)	Ø72x25	Dimensions of probe (mm)	Ø50x8
Cable max. length (cm)	85	Electrocod	051A

DIMENSIONAL



TECHNICAL SYMBOLOGY

IP

IP20

STANDARDS/APPROVALS

