

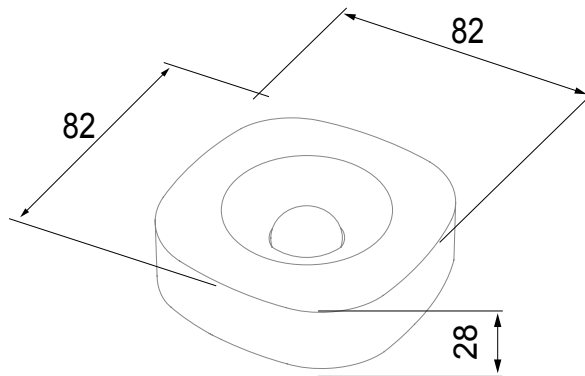

Wirelessly connected device with Zigbee protocol from the ChoruSmart system. It can be used with Home Gateway for "CONNECTED SMART HOME" solutions and with Smart Gateway for "HOME AND BUILDING PRO" solutions. Ideal for residential and small commercial offices, new builds and renovations. Zigbee technology is a secure and reliable technology in which data is encrypted and every node within the network ensures reachability across all devices (mesh network). This device can also be used without Home Gateway and Smart Gateway (manual configuration with dip-switch or via IoT Configurator), in which case supervision via the app is not possible.

Category	Motion sensor	Colour	White
Communication protocol	Zigbee (IEEE 802.15.4)	Supply voltage	Battery powered
Power supply batteries	CR123 replaceable	Output power	3 dBm
Light sensor	3...70.000 lux	Max range	6 m
Horizontal bearing angle	± 45°	Vertical bearing angle	± 45°
Temperature sensor	0...50 °C	Standard	2014/53/EU, EN 60669-2-1, ETSI EN 300 328
IP degree	IP30	Working temperature	0 ÷ +50 °C
Stocking temperature	-20 ÷ +80 °C	Relative humidity (non-condensative)	10 ÷ 95%
Dimensions LxHxD (mm)	82x82x28	Electrocod	051A

DIMENSIONAL



TECHNICAL SYMBOLOGY

IP

IP30

STANDARDS/APPROVALS

