

The System modular devices allow the creation of infinite combinations of devices and plates, through a complete range that covers all design, functional and installation needs. Colours and finishes: satin black, elegant and classy. The range includes control units, socket-outlets, breakers, indicators, connectors and devices for the control, safety and comfort of your home. Item designated solely for export to a limited number of countries outside of the European Union or where European Directives are not applied.

| | | | |
|--------------|------------------|--------------------|---------------------|
| Category | TV socket-outlet | Description | Terminated - 75 ohm |
| Type | - | Colour | Black |
| Attenuation | 20 dB | Frequency | 40-860 MHz |
| Shielding | - | For connector type | IEC Female Ø 9,5 mm |
| Standard | - | No. SYSTEM modules | 1 |
| Cable fixing | With screw | Case | - |
| Material | Technopolymer | Electrocod | 0131 |

DIMENSIONAL

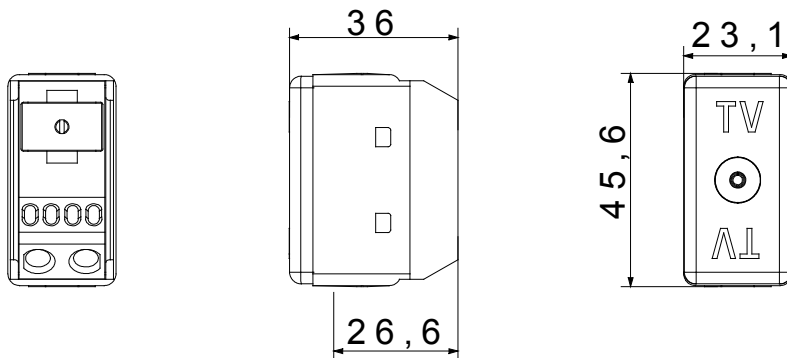

STANDARDS/APPROVALS

