

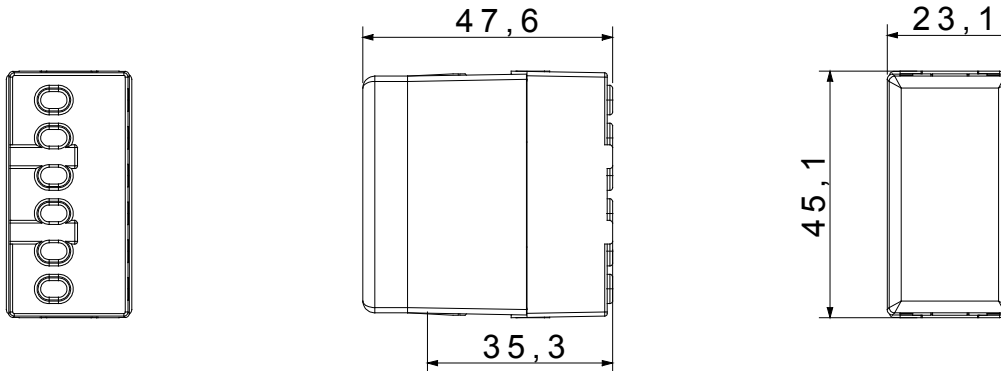

The System modular devices allow the creation of infinite combinations of devices and plates, through a complete range that covers all design, functional and installation needs. Colours and finishes: satin black, elegant and classy. The range includes control units, socket-outlets, breakers, indicators, connectors and devices for the control, safety and comfort of your home.

Category	Relay	Output contacts	10 AX 250 V ac
Description	Step-step 2P	Colour	Black
No. of poles	2	Voltage	230 V ac
Standard	EN 60669-1 / EN 60669-2-2	Frequency	50 Hz
Resistance at test voltage	2000 V at 50 Hz for 1 minute	Insulation resistance	> 5 MOhm
Wiring terminals	With screw	Prolonged operation switch (no.of position changes)	40.000 at In 250 V ac cosφ=0,6
Thermo-pressure with ball	125 °C	Glow Wire Test	850 °C
Terminal grip on cable traction	> 50 N	Terminal tightening capacity stranded cables (mm ²)	1x4 / 2x2,5
Terminal tightening capacity solid cables (mm ²)	2x2,5	No. SYSTEM modules	1
Rated power (AC1)	0 VA	Rated power (AC15)	0 VA
230V incandescent/halogen lamps	800 W	Fluorescent lamps with electronic ballast	400 W
Fluorescent lamps with compensated ballast	360 W	CFL lamps	200 W
230V LED lamps	200 W	Halogen/LED lamps with electronic transformer	200 W
Halogen/LED lamps with electromechanical transformer	400 W	Material	Technopolymer
Electrocod	140		

DIMENSIONAL



TECHNICAL SYMBOLOGY



STANDARDS/APPROVALS

