

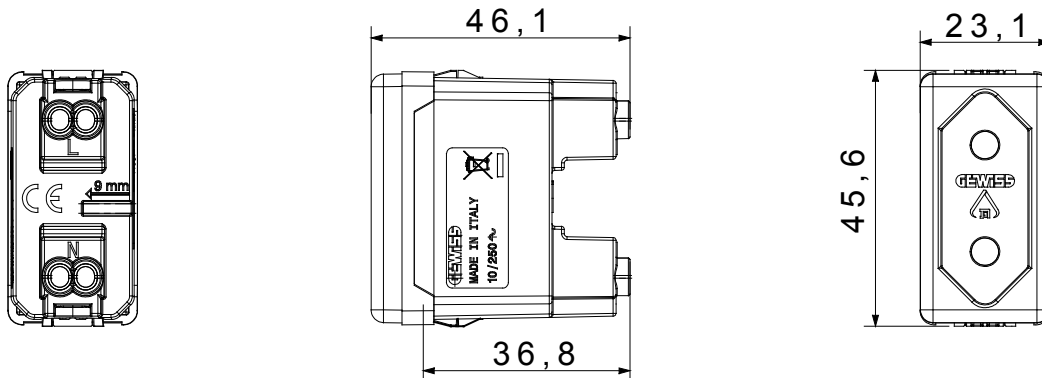

The System modular devices make it possible to create infinite combination between devices and plates, thanks to a complete range that is able to satisfy all design, functional and installation requirements. Colour and finiture: glossy white, bright and versatile. Ideal for flush-mounting solutions (for rectangular or square boxes), surface-mounting solutions, and for special applications. The range includes commands, socket-outlets, protection, indicators, connectors and devices for the control, safety and comfort of your home.

Category	Power	Description	2P - 10 A
Colour	White	Earth pit	-
Standard	Israeli	Characteristics	With safety shields
For plug pins	Round Ø 4 mm	Wiring terminals	With screw
Standard	IEC 60884-1; SI 32 part 1.1	Resistance at test voltage	2000 V at 50 Hz for 1 minute
Prolonged operation switch (no.of position changes)	10.000 at In 250 V ac cosφ=0,8	Thermo-pressure with ball	125 °C
Glow Wire Test	850 °C	Terminal grip on cable traction	> 50 N
Terminal tightening capacity stranded cables (mm²)	min. 0,75 - max. 2x4	Terminal tightening capacity solid cables (mm²)	min. 0,5 - max. 2x2,5
No. SYSTEM modules	1	Material	Technopolymer
Electrocod	0131		

### DIMENSIONAL



### TECHNICAL SYMBOLOGY



### STANDARDS/APPROVALS

