

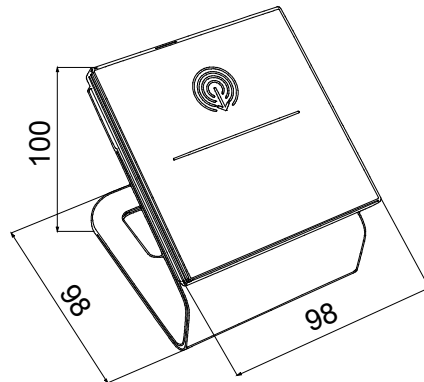

The card programmer allows the writing/reading of cards with RFID-MIFARE® transponder technology (use cards from the Gewiss catalogue). Powered directly via USB cable connected to a USB port of the card programming PC (e.g. reception). To program the cards, a client license must be installed on the PC (included in the GW Host software package). The device is supplied already installed in a table box complete with technopolymer front plate and USB cable.

Catégorie	Transponder card programmer unit MIFARE®	Couleur	Noir
Material	Front plate in technopolymer	Installation	De table
Alimentation	Via USB	Current absorbed by power supply	Max 160 mA a 5V
Interfaces	USB	Technologie	Transponder RFID-MIFARE®
Dimensions LxHxP (mm)	98x98x100	Indice de protection	IP20
Norme	Directive RED 2014/53/UE; Directive RoHS 2011/65/EU + 2015/863; EN 63044-3; EN 63044-5-1; EN 63044-5-2; EN 300 330; EN 301 489-3; EN IEC 63000		

DIMENSIONS



SYMBOLE TECHNIQUE

IP

IP20

NORMES ET HOMOLOGATIONS

