

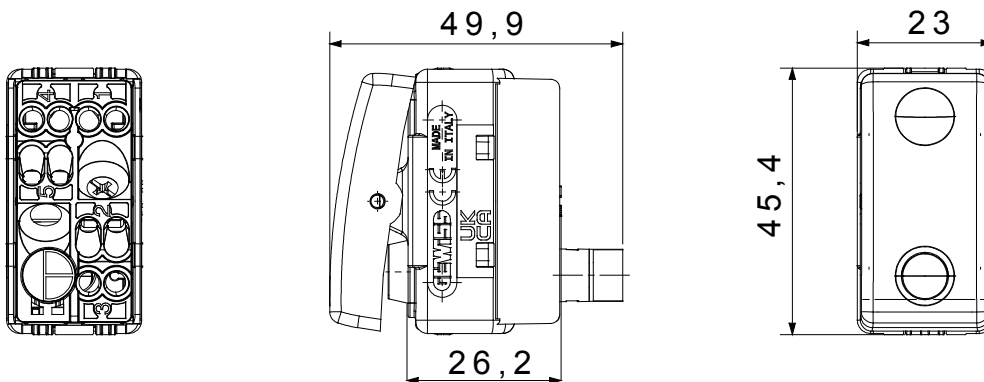

The System modular devices make it possible to create infinite combination between devices and plates, thanks to a complete range that is able to satisfy all design, functional and installation requirements. Colour and finiture: glossy white, bright and versatile
The range includes commands, socket- outlets, protection, indicators, connectors and devices for the control, safety and comfort of your home.

| | | | |
|---|------------------------------------|---|----------------------------------|
| Catégorie | Bouton-poussoir | Bouton | Avec lentille neutre remplaçable |
| Symbole | - | Couleur | Blanc |
| Description | 1P NO - 10 A lumineux | Tension | 250 V ca |
| Unité de signalisation | LED 12/24Vac/dc (0,4W) white color | Norme | EN 60669-1 |
| Tenue à la tension d'essai | 2000 V à 50 Hz pendant 1 minute | Résistance d'isolement | > 5 MOhm |
| Bornes de câblage | À vis | Endurance (Nbre de manœuvres) | 40 000 à In 250 V ca cosφ=0,6 |
| Thermopression avec bille | 125 °C | Test du fil incandescent | 850 °C |
| Résistance des bornes à la traction des câbles | > 50 N | Capacité de serrage des bornes câbles souples (mm²) | min. 0,75 - max. 2x4 |
| Capacité de serrage des bornes câbles rigides (mm²) | min. 0,5 - max. 2x2,5 | Nb modules System | 1 |
| Matière | Technopolymère | Electrocod | 0130 |

DIMENSIONS



SYMBOLE TECHNIQUE



NORMES ET HOMOLOGATIONS

