

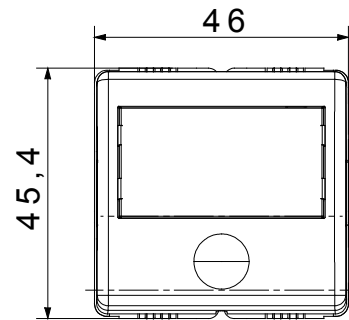

The System modular devices allow the creation of infinite combinations of devices and plates, through a complete range that covers all design, functional and installation needs. Colours and finishes: satin black, elegant and classy. The range includes control units, socket-outlets, breakers, indicators, connectors and devices for the control, safety and comfort of your home.

Categoría	Pulsador	Tipo	Placa portatarjetas
Color	Negro	Descripción	1P NA - 10A
Tensión	250 V ac	Norma de referencia	EN 60669-1
Resistencia a la tensión de prueba	2000 V a 50 Hz durante 1 minuto	Resistencia de aislamiento	> 5 MOhm
Regleta de cableado	De tornillo	Base de funcionamiento prolongado (n° de maniobras)	40.000 a In 250 Vac cosφ=0,6
Retención del borne en tracción al cable	> 50 N	Capacidad de apriete cable flexible (mm ²)	min. 0,75 - max. 2x4
Capacidad de apriete cable rígido (mm ²)	min. 0,5 - max. 2x2,5	Lámpara	Casquillo S6x36 mm
Termopresión con bola	125 °C	Tensión lámpara	12-24 V ac/dc
Prueba del hilo incandescente	850 °C	Potencia lámpara	2 W
N. módulos System	2	Material	Tecnopolímero
Código Electrocod	0130		

DIMENSIONAL

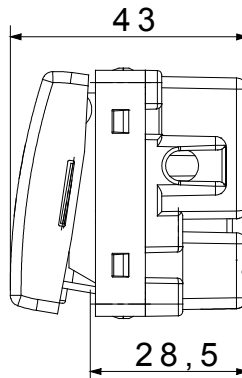
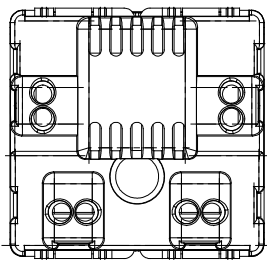

SIMBOLOGÍA TÉCNICA



MARCAS/APROBACIONES

