

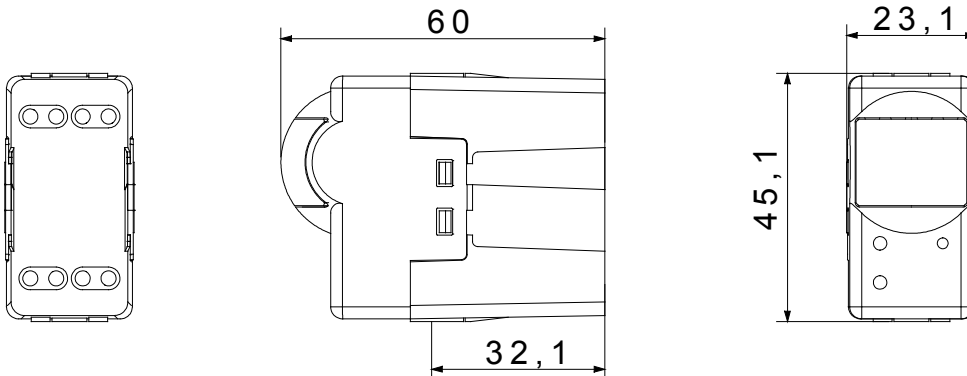

The System modular devices allow the creation of infinite combinations of devices and plates, through a complete range that covers all design, functional and installation needs. Colours and finishes: satin black, elegant and classy. The range includes control units, socket-outlets, breakers, indicators, connectors and devices for the control, safety and comfort of your home.

Output contacts	1NO 3A(AC1) 250V ac	Colour	Black
Supply voltage	230V ac - 50/60Hz	Technology	Infrared
Standard	EN 60669-1, EN 60669-2-1	Resistance at test voltage	2000 V at 50 Hz for 1 minute
Insulation resistance	> 5 MOhm	Wiring terminals	With screw
Prolonged operation switch (no.of position changes)	40.000 at In 250 V ac cosφ=0,6	Thermo-pressure with ball	125 °C
Glow Wire Test	850 °C	Terminal grip on cable traction	> 50 N
Terminal tightening capacity stranded cables (mm ²)	min. 0,75 - max. 2x4	Terminal tightening capacity solid cables (mm ²)	min. 0,5 - max. 2x2,5
No. SYSTEM modules	1	Material	Technopolymer
Electrocod	0513		

DIMENSIONAL



TECHNICAL SYMBOLOGY



STANDARDS/APPROVALS

