

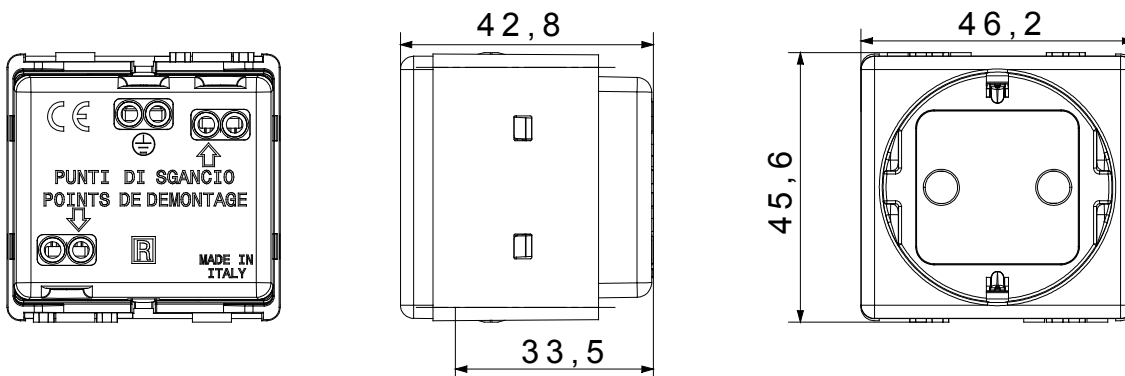

The System modular devices allow the creation of infinite combinations of devices and plates, through a complete range that covers all design, functional and installation needs. Colours and finishes: satin black, elegant and classy. Ideal for flush-mounted solutions (for rectangular or square boxes), surface-mounted solutions and special applications. The range includes control units, socket-outlets, breakers, indicators, connectors and devices for the control, safety and comfort of your home

Kategorie	Steckdose	Beschreibung	2P+E - 16A
Farbe	Schwarz	Spannung	250 V ac
Schutzleiter-anschluss	-	Standard	Deutsch
Merkmale	Mit Schrauben	Für Steckstifte	Ø 4,8 mm
Anschlussklemmen	Schraubklemmen	Norm	IEC 60884-1; UNE 20315-1-1; UNE 20315-1-2
Widerstand bei Prüfspannung	2000 V bei 50 Hz für 1 Minute	Anzahl Betätigungen (Änderung Schaltstellung).	10.000 bei In 250 V ac cosφ=0,8
Kugeldruckprüfung	125 °C	Glühdrahtprüfung	850 °C
Haltekraft Klemme	> 50 N	Anschluss feindrähtig (mm²)	min. 0,75 - max. 2x4
Anschluss massiv (mm²)	min. 0,5 - max. 2x2,5	Anz. SYSTEM Module	2
Material	Technopolymer	Electrocod	0131

### Abmessungen



### Technische Symbole



### Normen / Richtlinien

