

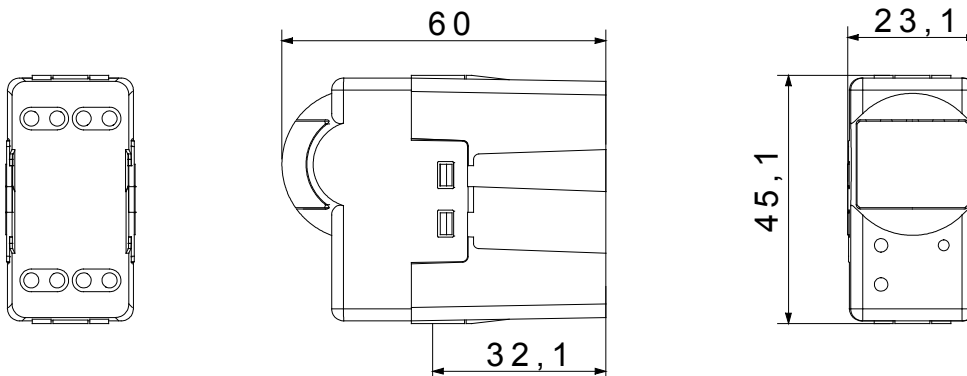

The System modular devices allow the creation of infinite combinations of devices and plates, through a complete range that covers all design, functional and installation needs. Colours and finishes: satin black, elegant and classy. The range includes control units, socket-outlets, breakers, indicators, connectors and devices for the control, safety and comfort of your home.

Ausgangs- kontakt	1S 3A (AC1) 250V ac	Farbe	Schwarz
Versorgungs- spannung	230V ac - 50/60Hz	Technologie	Infrarot
Norm	EN 60669-1, EN 60669-2-1	Widerstand bei Prüfspannung	2000 V bei 50 Hz für 1 Minute
Isolationswiderstand	> 5 MOhm	Anschlussklemmen	Mit Schrauben
Anzahl Betätigungen (Änderung Schaltstellung).	40.000 bei In 250 V ac cosφ=0,6	Kugeldruckprüfung	125 °C
Glühdrahtprüfung	850 °C	Haltekraft Klemme	> 50 N
Anschluss feindrähtig (mm²)	min. 0,75 - max. 2x4	Anschluss massiv (mm²)	min. 0,5 - max. 2x2,5
Anz. SYSTEM Module	1	Material	Technopolymer
Electrocod	0513		

Abmessungen



Technische Symbole



Normen / Richtlinien

