

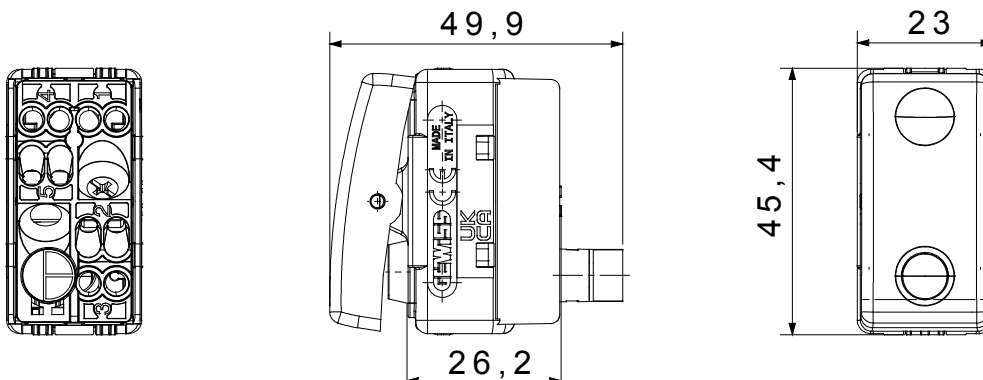

The System modular devices allow the creation of infinite combinations of devices and plates, through a complete range that covers all design, functional and installation needs. Colours and finishes: satin black, elegant and classy. The range includes control units, socket-outlets, breakers, indicators, connectors and devices for the control, safety and comfort of your home.

Kategorie	Taster	Taster	Mit austauschbarer neutraler Linse
Symbol	-	Farbe	Schwarz
Beschreibung	1P S - 10 A beleuchtet	Spannung	250 V ac
Kontroll- leuchte	LED 12/24Vac/dc (0,4W) white color	Norm	EN 60669-1
Widerstand bei Prüfspannung	2000 V bei 50 Hz für 1 Minute	Isolationswiderstand	> 5 MOhm
Anschlussklemmen	Mit Schrauben	Anzahl Betätigungen (Änderung Schaltstellung).	40.000 bei In 250 V ac cosφ=0,6
Kugeldruckprüfung	125 °C	Glühdrahtprüfung	850 °C
Haltekraft Klemme	> 50 N	Anschluss feindrätig (mm²)	min. 0,75 - max. 2x4
Anschluss massiv (mm²)	min. 0,5 - max. 2x2,5	Anz. SYSTEM Module	1
Material	Technopolymer	Electrocod	0130

Abmessungen



Technische Symbole



Normen / Richtlinien

