

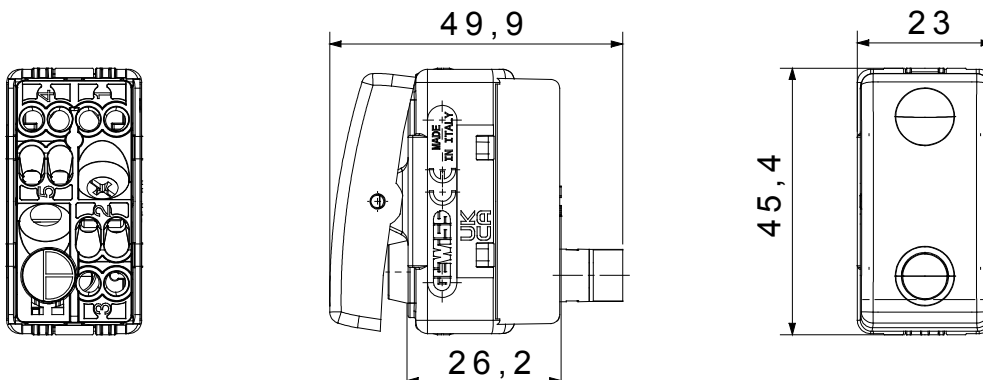

The System modular devices make it possible to create infinite combination between devices and plates, thanks to a complete range that is able to satisfy all design, functional and installation requirements. Colour and finiture: glossy white, bright and versatile
Ideal for flush-mounting solutions (for rectangular or square boxes), surface-mounting solutions, and for special applications. The range includes commands, socket- outlets, protection, indicators, connectors and devices for the control, safety and comfort of your home.

Kategorie	Wechselschalter	Taster	Mit austauschbarer neutraler Linse
Symbol		- Farbe	Weiss
Beschreibung	1P - 16 AX beleuchtet	Spannung	250 V ac
Kontroll- leuchte	Miniatur- Lampe – Leuchtstoffröhre – 230 Vac – 0,4 W – Rot	Norm	EN 60669-1
Widerstand bei Prüfspannung	2000 V bei 50 Hz für 1 Minute	Leistung LED Lampen 230V	200 W
Isolationswiderstand	> 5 MOhm	Anschlussklemmen	Mit Schrauben
Anzahl Betätigungen (Änderung Schaltstellung).	40.000 bei In 250 V ac $\cos\phi=0,6$	Kugeldruckprüfung	125 °C
Glühdrahtprüfung	850 °C	Haltekraft Klemme	> 50 N
Anschluss feindrätig (mm ²)	min. 0,75 - max. 2x4	Anschluss massiv (mm ²)	min. 0,5 - max. 2x2,5
Anz. SYSTEM Module	1	Material	Technopolymer
Electrocod	0130		

Abmessungen



Technische Symbole



Normen / Richtlinien

