

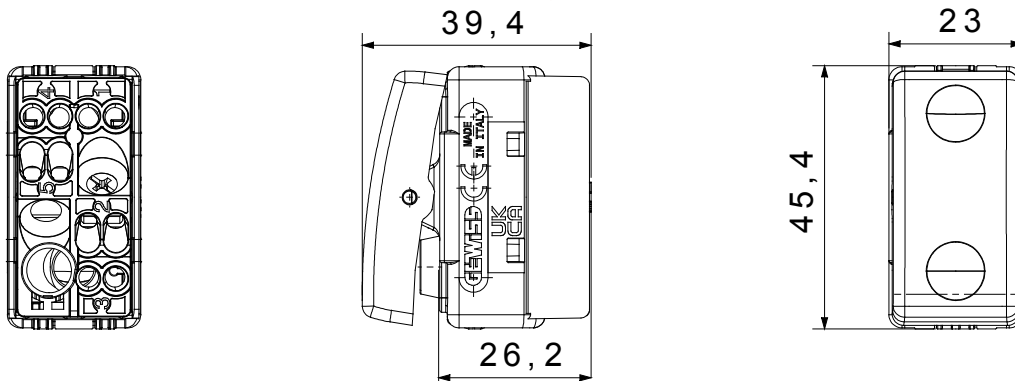

The System modular devices make it possible to create infinite combination between devices and plates, thanks to a complete range that is able to satisfy all design, functional and installation requirements. Colour and finiture: glossy white, bright and versatile  
The range includes commands, socket- outlets, protection, indicators, connectors and devices for the control, safety and comfort of your home.

Kategorie	Taster	Taster	Mit Verriegelung
Symbol	Doppelte Ringe	Farbe	Weiss
Beschreibung	1P S+S - 10 A	Spannung	250 V ac
Kontroll- leuchte	-	Norm	EN 60669-1
Widerstand bei Prüfspannung	2000 V bei 50 Hz für 1 Minute	Isolationswiderstand	> 5 MOhm
Anschlussklemmen	Mit Schrauben	Anzahl Betätigungen (Änderung Schaltstellung).	40.000 bei In 250 V ac cosφ=0,6
Kugeldruckprüfung	125 °C	Glühdrahtprüfung	850 °C
Haltekraft Klemme	> 50 N	Anschluss feindrähtig (mm²)	min. 0,75 - max. 2x4
Anschluss massiv (mm²)	min. 0,5 - max. 2x2,5	Anz. SYSTEM Module	1
Material	Technopolymer	Electrocod	0130

### Abmessungen



### Technische Symbole



### Normen / Richtlinien

