

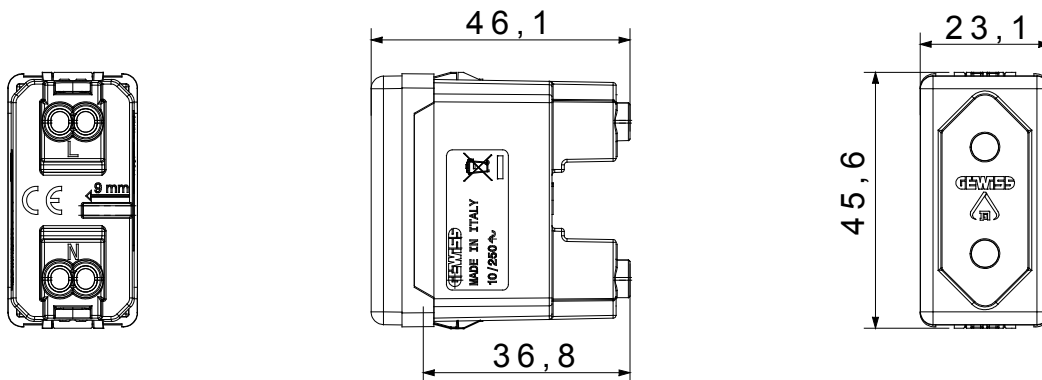

The System modular devices make it possible to create infinite combination between devices and plates, thanks to a complete range that is able to satisfy all design, functional and installation requirements. Colour and finiture: glossy white, bright and versatile
Ideal for flush-mounting solutions (for rectangular or square boxes), surface-mounting solutions, and for special applications. The range includes commands, socket- outlets, protection, indicators, connectors and devices for the control, safety and comfort of your home.

Beschreibung	2P - 10 A	Farbe	Weiss
Schutzleiter- anschluss	-	Standard	Israelisch
Merkmale	Mit erhöhtem Berührungsschutz	Für Steckstifte	Rund Ø 4 mm
Norm	IEC 60884-1	Widerstand bei Prüfspannung	2000 V bei 50 Hz für 1 Minute
Anzahl Betätigungen (Änderung Schaltstellung).	10.000 bei In 250 V ac cosφ=0,8	Kugeldruckprüfung	125 °C
Glühdrahtprüfung	850 °C	Haltekraft Klemme	> 50 N
Anschluss feindrätig (mm²)	min. 0,75 - max. 2x4	Anschluss massiv (mm²)	min. 0,5 - max. 2x2,5
Anz. SYSTEM Module	1	Material	Technopolymer
Electrocod	0131		

Abmessungen



Technische Symbole



Normen / Richtlinien

