

Spatium PRO | 2 is a high-power LED floodlight, with a high-emittance LES (light emitted surface), suitable for lighting professional and semi-professional sporting facilities. The floodlight has a graphite grey finish with trivalent treatment for maximum resistance to oxidation and is equipped with an integrated 'self-cleaning' heat dissipation system. It consists of 2 modules, each with a bleed and anti-condensation valve, protected from accidental impact. The rotation system between the brackets and optic modules is of the truncated-conical aluminium type, with an integrated goniometer in the bracket for easy control of orientation, and screw and grub screw fastening, which guarantees the fastness of each individual module over time. The floodlight is available in the following colour temperatures 4,000K or 5,700K and colour rendering CRI>70, CRI>80 o CRI>90 (TLCI>80). In addition, the range offers 6 types of circular optics, from 8° up to 40°, 1 symmetrical/elliptical optic and 2 asymmetric optics. The T.I.R.Ex. optic system developed by GEWISS with lenses in PMMA HT (high-transparency), gives complete control over the light beam, allowing for great flexibility in any project design, with high qualitative and quantitative performance. The power supply box can be installed on the bracket or remote, and is protected from surges up to 10KV, either in differential or common mode, with a single cable. The range requires a DALI2 or DMX-RDM power supply to permit the greatest flexibility in the creation of lighting scenarios, even of great complexity.

Insulation class	I	IP degree	IP66
Mechanical resistance	IK08	Voltage	220-400 V - 50/60 Hz
Versions	DMX	Description	Stadium PRO 2 DMX 400V power pack
Weight (kg)	5.4	Series	Stadium PRO
Application	Indoor / Outdoor	Number of modules	2M
Warranty	5 years	Overtolerance resistance	DM 10KV / CM 10KV
Driver failure rate	F10 >100.000h Tq25°C		

DIMENSIONAL

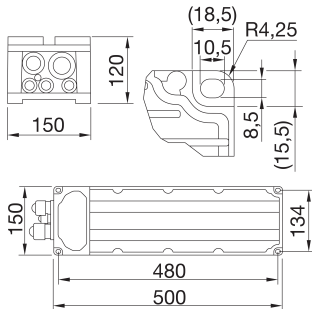

PHOTOMETRIC DISTRIBUTION

TECHNICAL SYMBOLOGY



IP

IP66

IK

IK08



STANDARDS/APPROVALS

