

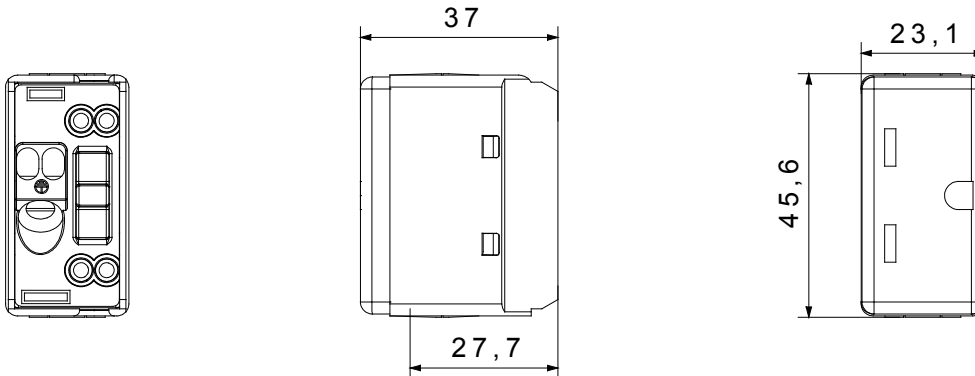

The System modular devices allow the creation of infinite combinations of devices and plates, through a complete range that covers all design, functional and installation needs. Colours and finishes: satin black, elegant and classy. Ideal for flush-mounted solutions (for rectangular or square boxes), surface-mounted solutions and special applications. The range includes control units, socket-outlets, breakers, indicators, connectors and devices for the control, safety and comfort of your home

Descriere	2P+E - 15A 250V c.a.	Culoare	Negru
Tensiune	250/125V CA	Groapă de pământ	-
Standard	SUA	Caracteristici	-
Pentru știfturi de conectare	Aliniate pe verticală	Standard	IEC 60884-1
Rezistența la tensiunea de test	2000 V la 50 Hz timp de 1 minut	Comutator de funcționare prelungit (nr. de modificări)	10000 cicluri la 250 V ac cosφ=0,8
Termo-presiune cu bilă	125 °C	Test de încercare cu fir incandescent	850 °C
Prinderea bornei la tracțiunea cablului	> 50 N	Capacitate de strângere borne cabluri torsadate (mm <sup>2</sup> )	min. 0,75 - max. 2x4
Capacitate de strângere a bornelor cabluri solide (mm <sup>2</sup> )	min. 0,5 - max. 2x2,5	Nr. Module DE SISTEM	1
Material	Tehnopolimer	Electrocod	0131

### DIMENSIONAL



### TECHNICAL SYMBOLOGY



### STANDARDS/APPROVALS

