

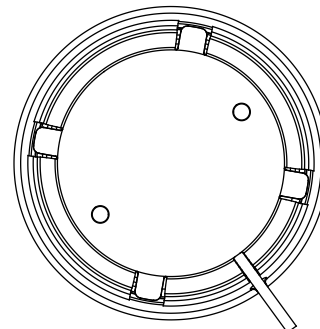

Accessorio per montaggio a parete del sensore acqua connesso GWA1514.

| | | | |
|---------------------------|---------------------------------|------------------------------------|------------|
| Categoria | Supporto a parete sensore acqua | Colore | Bianco |
| Materiale | Tecnopolimero | Norma di riferimento | 2014/53/EU |
| Grado di protezione | IP20 | Temperatura di funzionamento | 0 ÷ +50 °C |
| Temperatura di stoccaggio | -20 ÷ +80 °C | Umidità relativa (non condensante) | 10 ÷ 95% |
| Dimensione supporto (mm) | Ø72x25 | Dimensioni sonda (mm) | Ø50x8 |
| Lunghezza max. cavo (cm) | 85 | Codice Electrocod | 051A |

DIMENSIONALE

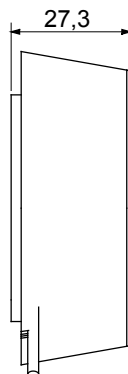
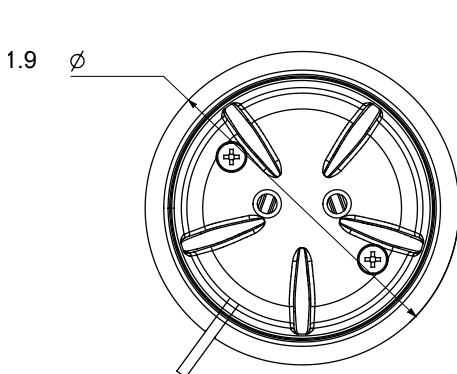

SIMBOLOGIA TECNICA

IP

IP20

MARCHI/APPROVAZIONI

