

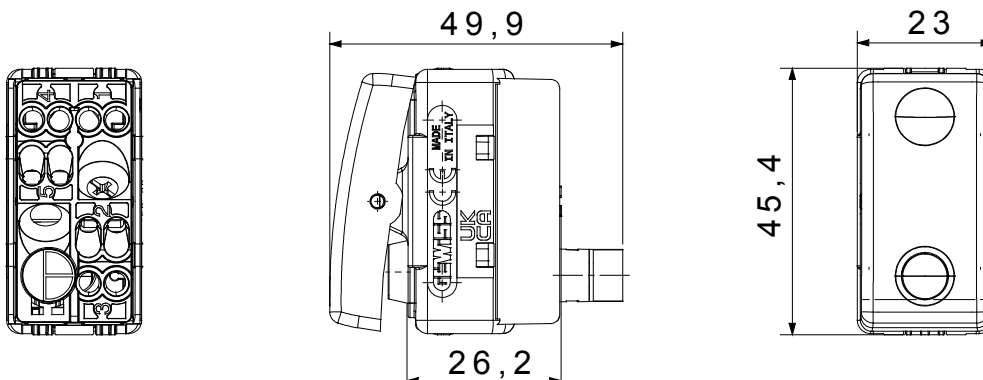

The System modular devices allow the creation of infinite combinations of devices and plates, through a complete range that covers all design, functional and installation needs. Colours and finishes: satin black, elegant and classy. Ideal for flush-mounted solutions (for rectangular or square boxes), surface-mounted solutions and special applications. The range includes control units, socket-outlets, breakers, indicators, connectors and devices for the control, safety and comfort of your home

Kategorie	Wechselschalter	Taster	Mit austauschbarer neutraler Linse
Symbol		- Farbe	Schwarz
Beschreibung	1P - 16 AX beleuchtet	Spannung	250 V ac
Kontroll- leuchte		- Norm	EN 60669-1
Widerstand bei Prüfspannung	2000 V bei 50 Hz für 1 Minute	Leistung LED Lampen 230V	200 W
Isolationswiderstand	> 5 MOhm	Anschlussklemmen	Mit Schrauben
Anzahl Betätigungen (Änderung Schaltstellung).	40.000 bei In 250 V ac $\cos\phi=0,6$	Kugeldruckprüfung	125 °C
Glühdrahtprüfung	850 °C	Haltekraft Klemme	> 50 N
Anschluss feindrätig (mm ²)	min. 0,75 - max. 2x4	Anschluss massiv (mm ²)	min. 0,5 - max. 2x2,5
Anz. SYSTEM Module	1	Material	Technopolymer
Electrocod	0130		

Abmessungen



Technische Symbole



Normen / Richtlinien

