

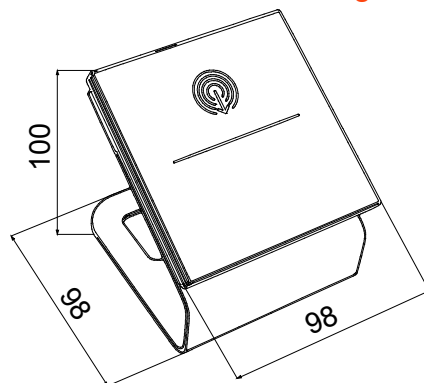

The card programmer allows the writing/reading of cards with RFID-MIFARE® transponder technology (use cards from the Gewiss catalogue). Powered directly via USB cable connected to a USB port of the card programming PC (e.g. reception). To program the cards, a client license must be installed on the PC (included in the GW Host software package). The device is supplied already installed in a table box complete with technopolymer front plate and USB cable.

Kategorie	Transponder card programmer unit MIFARE®	Farbe	Schwarz
Material	Front plate in technopolymer	Installation	Freistehend
Spannungsversorgung	Via USB	Current absorbed by power supply	Max 160 mA a 5V
Schnittstellen	USB Verbinder	Technologie	Trasponder RFID-MIFARE®
Abmessungen BxHxT (mm)	98x98x100	Schutzart	IP20
Norm	Directive RED 2014/53/UE; Directive RoHS 2011/65/EU + 2015/863; EN 63044-3; EN 63044-5-1; EN 63044-5-2; EN 300 330; EN 301 489-3; EN IEC 63000		

Abmessungen



Technische Symbole

IP

IP20

Normen / Richtlinien

**UK
CA CE**