

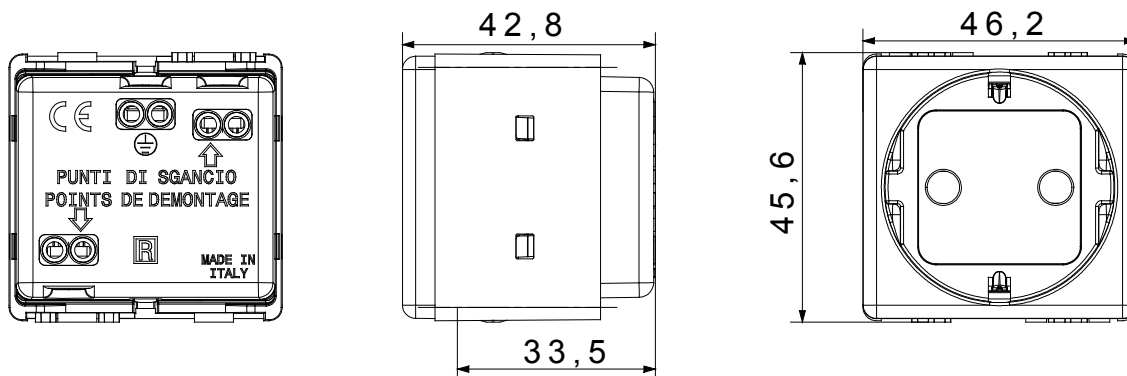

The System modular devices allow the creation of infinite combinations of devices and plates, through a complete range that covers all design, functional and installation needs. Colours and finishes: satin black, elegant and classy. Ideal for flush-mounted solutions (for rectangular or square boxes), surface-mounted solutions and special applications. The range includes control units, socket-outlets, breakers, indicators, connectors and devices for the control, safety and comfort of your home

Categoría	Base	Descripción	2P+T - 16A
Color	Negro	Tensión	250 V ac
Alveolo de tierra	-	Norma	Alemana
Características	De tornillo	Para clavijas	Ø 4,8 mm
Regleta de cableado	Bornes con tornillo	Norma de referencia	IEC 60884-1; UNE 20315-1-1; UNE 20315-1-2
Resistencia a la tensión de prueba	2000 V a 50 Hz durante 1 minuto	Base de funcionamiento prolongado (nº de maniobras)	10.000 a In 250 Vac cosφ=0,8
Termopresión con bola	125 °C	Prueba del hilo incandescente	850 °C
Retención del borne en tracción al cable	> 50 N	Capacidad de apriete cable flexible (mm²)	min. 0,75 - max. 2x4
Capacidad de apriete cable rígido (mm²)	min. 0,5 - max. 2x2,5	N. módulos System	2
Material	Tecnopolímero	Código Electrocod	0131

### DIMENSIONAL



### SIMBOLOGÍA TÉCNICA



### MARCAS/APROBACIONES

