



The System modular devices allow the creation of infinite combinations of devices and plates, through a complete range that covers all design, functional and installation needs. Colours and finishes: satin black, elegant and classy. The range includes control units, socket-outlets, breakers, indicators, connectors and devices for the control, safety and comfort of your home.

Item designated solely for export to a limited number of countries outside of the European Union or where European Directives are not applied.

Categoría	Base TV	Descripción	Derivación
Tipo	-	Color	Negro
Atenuación	20 dB	Frecuencia	40-860 MHz
Apantallado	-	Para conector tipo	IEC Female Ø 9,5 mm
Norma de referencia	-	N. módulos System	1
Fijación de cable	De tornillo	Estructura	-
Material	Tecnopolímero	Código Electrocod	0131

DIMENSIONAL

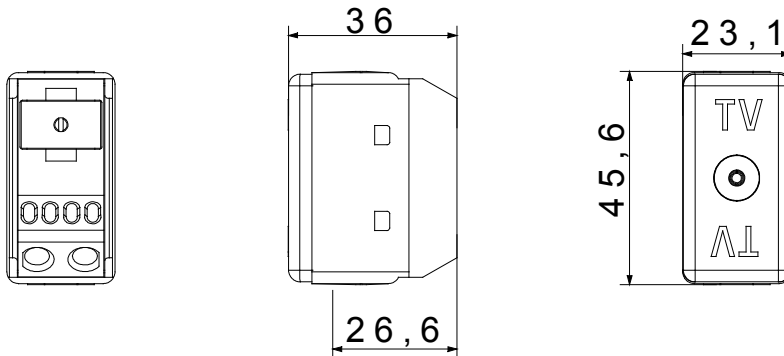

MARCAS/APROBACIONES

