

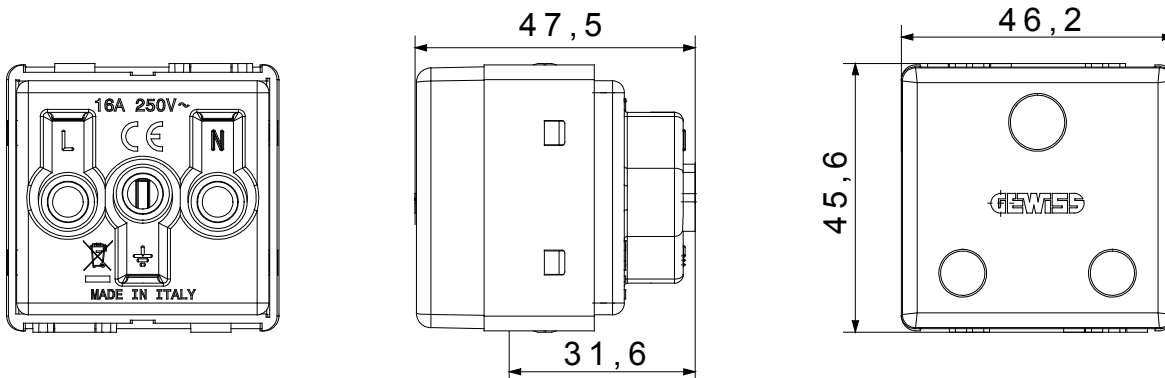

The System modular devices make it possible to create infinite combination between devices and plates, thanks to a complete range that is able to satisfy all design, functional and installation requirements. Colour and finiture: glossy white, bright and versatile
Ideal for flush-mounting solutions (for rectangular or square boxes), surface-mounting solutions, and for special applications. The range includes commands, socket- outlets, protection, indicators, connectors and devices for the control, safety and comfort of your home.

Descripción	2P+T - 16A	Color	Blanco
Tensión	250 V ac	Alveolo de tierra	-
Norma	UK	Características	Con obturadores de seguridad
Para clavijas	Ø 7 mm	Norma de referencia	IEC 60884-1
Resistencia a la tensión de prueba	2000 V a 50 Hz durante 1 minuto	Base de funcionamiento prolongado (nº de maniobras)	10.000 a In 250 Vac cosφ=0,8
Termopresión con bola	125 °C	Prueba del hilo incandescente	850 °C
Retención del borne en tracción al cable	> 50 N	Capacidad de apriete cable flexible (mm²)	min. 0,75 - max. 2x4
Capacidad de apriete cable rígido (mm²)	min. 0,5 - max. 2x2,5	N. módulos System	2
Material	Tecnopolímero	Código Electrocod	0131

DIMENSIONAL



SIMBOLOGÍA TÉCNICA



MARCAS/APROBACIONES

