

Unité d'alimentation à distance Smart [PRO] 3 x 2M

Classe isolement	I	Indice de protection	IP66
Résistance aux chocs	IK08	Type	Alimentation externe
Tension	220-400 V - 50/60 Hz	Versions	DMX
Description	Bloc d'alimentation DMX 3x2M 220-400 V	Poids (kg)	6.1
Série	Smart [PRO] 2.0	Application	Intérieur/ Extérieur
Nombre de modules	3x2M	Surface maximale exposée au vent	0.075 m ²
Garantie	5 ans	Température d'utilisation	-30°C + +50 °C
Protection contre les surcharges	DM 10 KV/CM 10 KV	Taux de défaillance du pilote	F10 = 50.000h Tq25°C

DIMENSIONS

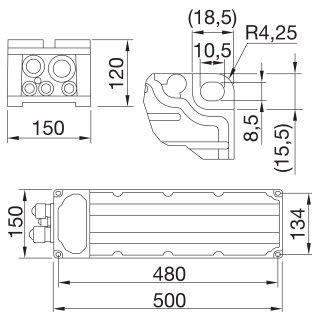

DISTRIBUTION PHOTOMETRIQUE

SYMBOLE TECHNIQUE



IP
IP66

IK
IK08



0.075 m²



NORMES ET HOMOLOGATIONS

