

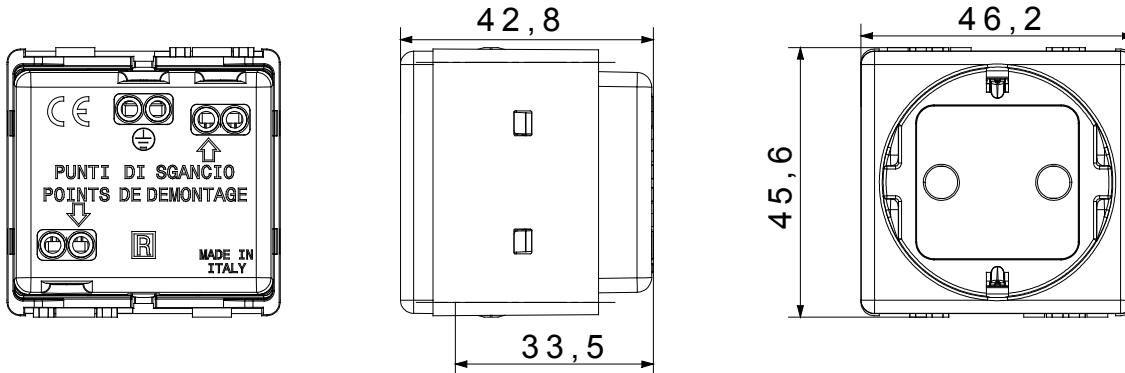

The System modular devices allow the creation of infinite combinations of devices and plates, through a complete range that covers all design, functional and installation needs. Colours and finishes: satin black, elegant and classy. Ideal for flush-mounted solutions (for rectangular or square boxes), surface-mounted solutions and special applications. The range includes control units, socket-outlets, breakers, indicators, connectors and devices for the control, safety and comfort of your home

Catégorie	Prise de courant	Description	2P+T - 16 A
Couleur	Noir	Tension	250 V ca
Alvéole de terre	-	Standard	Allemand
Caractéristiques	À vis	Pour broches	Ø 4,8 mm
Bornes de câblage	Bornes à vis	Norme	IEC 60884-1; UNE 20315-1-1; UNE 20315-1-2
Tenue à la tension d'essai	2000 V à 50 Hz pendant 1 minute	Endurance (Nbre de manœuvres)	10 000 à In 250 V ca cosφ=0,8
Thermopression avec bille	125 °C	Test du fil incandescent	850 °C
Résistance des bornes à la traction des câbles	> 50 N	Capacité de serrage des bornes câbles souples (mm ²)	min. 0,75 - max. 2x4
Capacité de serrage des bornes câbles rigides (mm ²)	min. 0,5 - max. 2x2,5	Nb modules System	2
Matière	Technopolymère	Electrocod	0131

DIMENSIONS



SYMBOLE TECHNIQUE



NORMES ET HOMOLOGATIONS

