

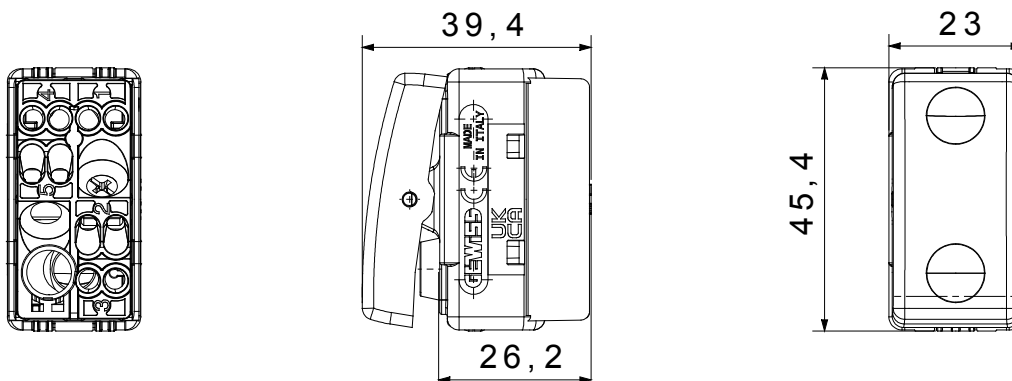

The System modular devices allow the creation of infinite combinations of devices and plates, through a complete range that covers all design, functional and installation needs. Colours and finishes: satin black, elegant and classy. Ideal for flush-mounted solutions (for rectangular or square boxes), surface-mounted solutions and special applications. The range includes control units, socket-outlets, breakers, indicators, connectors and devices for the control, safety and comfort of your home

Catégorie	Interrupteur	Bouton	Neutre
Symbole	0/1	Couleur	Noir
Description	2P - 16 AX	Tension	250 V ca
Unité de signalisation	-	Norme	EN 60669-1
Tenue à la tension d'essai	2000 V à 50 Hz pendant 1 minute	Puissance nominale de lampes LED 230 V	200 W
Résistance d'isolement	> 5 MOhm	Bornes de câblage	À vis
Endurance (Nbre de manœuvres)	40 000 à In 250 V ca cosφ=0,6	Thermopression avec bille	125 °C
Test du fil incandescent	850 °C	Résistance des bornes à la traction des câbles	> 50 N
Capacité de serrage des bornes câbles souples (mm²)	min. 0,75 - max. 2x4	Capacité de serrage des bornes câbles rigides (mm²)	min. 0,5 - max. 2x2,5
Nb modules System	1	Matière	Technopolymère
Electrocod	0130		

DIMENSIONS



SYMBOLE TECHNIQUE



NORMES ET HOMOLOGATIONS

