

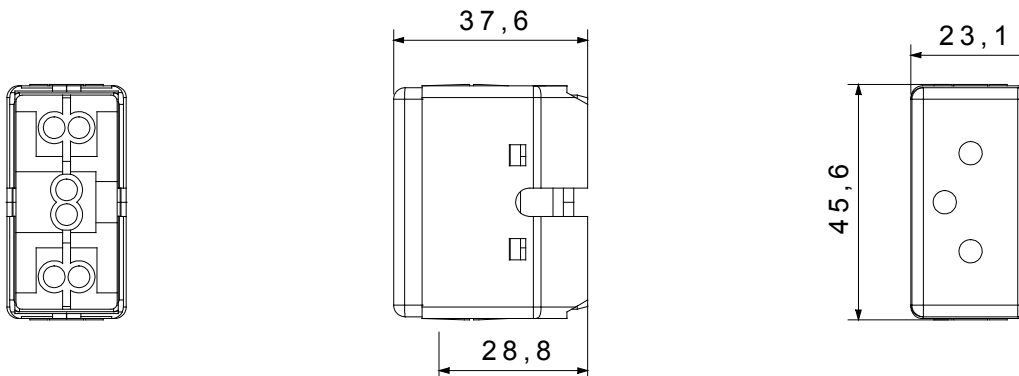

The System modular devices make it possible to create infinite combination between devices and plates, thanks to a complete range that is able to satisfy all design, functional and installation requirements. Colour and finiture: glossy white, bright and versatile  
Ideal for flush-mounting solutions (for rectangular or square boxes), surface-mounting solutions, and for special applications. The range includes commands, socket-outlets, protection, indicators, connectors and devices for the control, safety and comfort of your home.

Description	2P+T - 10A - type 12	Couleur	Blanc
Tension	250 V ca	Alvéole de terre	-
Standard	Suisse	Caractéristiques	-
Pour broches	Ø 4 mm	Norme	IEC 60884-1
Tenue à la tension d'essai	2000 V à 50 Hz pendant 1 minute	Endurance (Nbre de manœuvres)	10 000 à In 250 V ca cosφ=0,8
Thermopression avec bille	125 °C	Test du fil incandescent	850 °C
Résistance des bornes à la traction des câbles	> 50 N	Capacité de serrage des bornes câbles souples (mm²)	min. 0,75 - max. 2x4
Capacité de serrage des bornes câbles rigides (mm²)	min. 0,5 - max. 2x2,5	Nb modules System	1
Matière	Technopolymère	Electrocod	0131

### DIMENSIONS



### SYMBOLE TECHNIQUE



### NORMES ET HOMOLOGATIONS

