



The System modular devices allow the creation of infinite combinations of devices and plates, through a complete range that covers all design, functional and installation needs. Colours and finishes: glossy white, elegant and classy. The range includes control units, socket-outlets, breakers, indicators, connectors and devices for the control, safety and comfort of your home.

Item designated solely for export to a limited number of countries outside of the European Union or where European Directives are not applied.

Catégorie	Prise TV	Description	Dérivée
Type	-	Couleur	Blanc
Atténuation	20 dB	Fréquence	40-860 MHz
Blindage	-	Pour connecteur type	IEC-Femelle Ø 9,5 mm
Norme	-	Nb modules System	1
Fixation câble	À vis	Boîtier	-
Material	Technopolymère	Electrocod	0131

DIMENSIONS

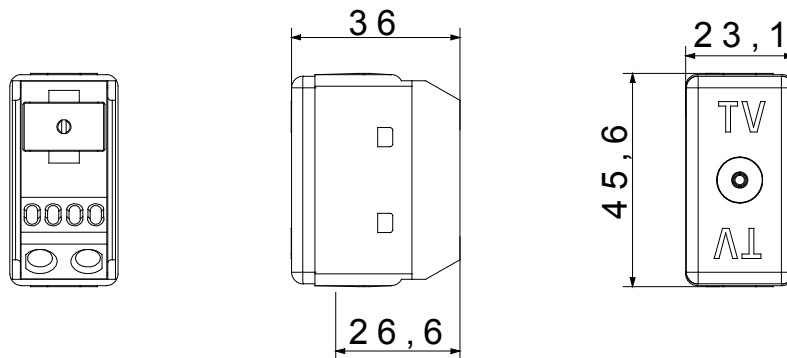

NORMES ET HOMOLOGATIONS

