

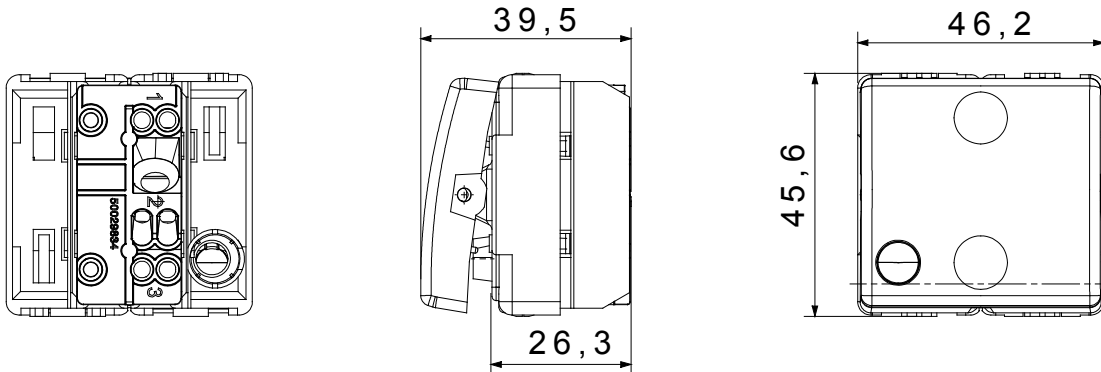

The System modular devices make it possible to create infinite combination between devices and plates, thanks to a complete range that is able to satisfy all design, functional and installation requirements. Colour and finiture: glossy white, bright and versatile
The range includes commands, socket- outlets, protection, indicators, connectors and devices for the control, safety and comfort of your home.

Kategorie	Taster	Taster	Mit Diffusor
Farbe	Weiss	Beschreibung	1P S - 10 A - beleuchtbar
Spannung	250 V ac	Norm	EN 60669-1
Widerstand bei Prüfspannung	2000 V bei 50 Hz für 1 Minute	Isolationswiderstand	> 5 MOhm
Anschlussklemmen	Mit Schrauben	Anzahl Betätigungen (Änderung Schaltstellung).	40.000 bei In 250 V ac cosφ=0,6
Haltekraft Klemme	> 50 N	Anschluss feindrätig (mm²)	min. 0,75 - max. 2x4
Anschluss massiv (mm²)	min. 0,5 - max. 2x2,5	Kugeldruckprüfung	125 °C
Glühdrahtprüfung	850 °C	Anz. SYSTEM Module	2
Material	Technopolymer	Electrocod	0130

Abmessungen



Technische Symbole



Normen / Richtlinien

