



The System modular devices allow the creation of infinite combinations of devices and plates, through a complete range that covers all design, functional and installation needs. Colours and finishes: glossy white, elegant and classy. The range includes control units, socket-outlets, breakers, indicators, connectors and devices for the control, safety and comfort of your home.

Item designated solely for export to a limited number of countries outside of the European Union or where European Directives are not applied.

Kategorie	TV Dose	Beschreibung	Terminiert - 75 Ohm
Typ	-	Farbe	Weiss
Dämpfungswerte	20 dB	Frequenz	40-860 MHz
Schirmung	-	Für Verbinder Typ	IEC-Buchsel Ø 9,5 mm
Norm	-	Anz. SYSTEM Module	1
Kabelfixierung	Mit Schrauben	Gehäuse	-
Material	Technopolymer	Electrocod	0131

### Abmessungen

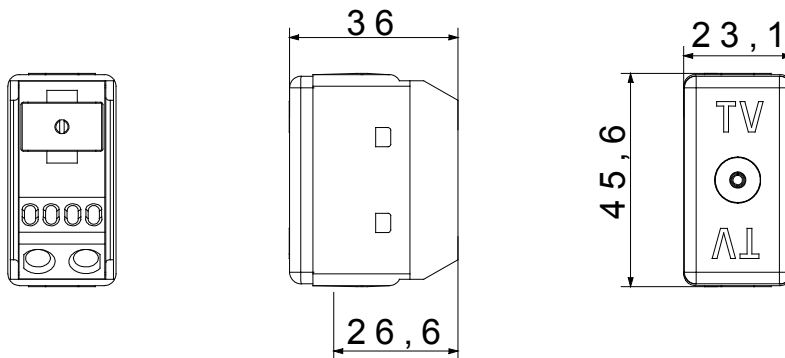

### Normen / Richtlinien

