

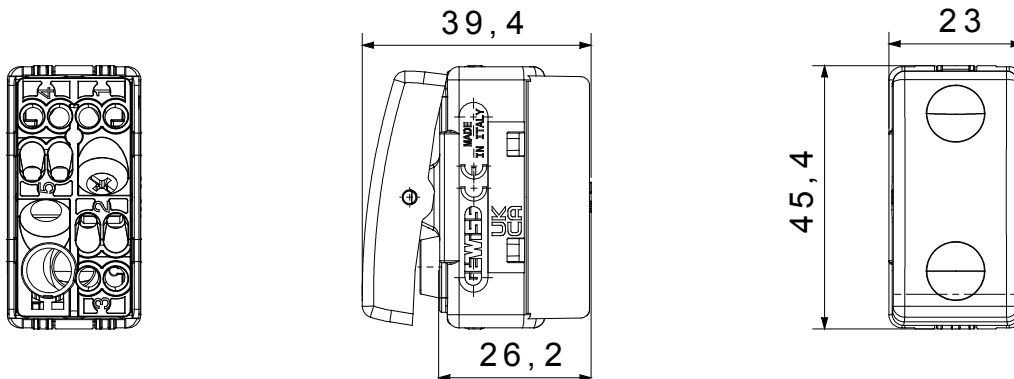

The System modular devices make it possible to create infinite combination between devices and plates, thanks to a complete range that is able to satisfy all design, functional and installation requirements. Colour and finiture: glossy white, bright and versatile
The range includes commands, socket- outlets, protection, indicators, connectors and devices for the control, safety and comfort of your home.

Catégorie	Bouton-poussoir	Bouton	Avec verrouillage
Symbole	Doubles cercles	Couleur	Blanc
Description	1P NO+NO - 10 A	Tension	250 V ca
Unité de signalisation	-	Norme	EN 60669-1
Tenue à la tension d'essai	2000 V à 50 Hz pendant 1 minute	Résistance d'isolement	> 5 MOhm
Bornes de câblage	À vis	Endurance (Nbre de manœuvres)	40 000 à In 250 V ca cosφ=0,6
Thermopression avec bille	125 °C	Test du fil incandescent	850 °C
Résistance des bornes à la traction des câbles	> 50 N	Capacité de serrage des bornes câbles souples (mm²)	min. 0,75 - max. 2x4
Capacité de serrage des bornes câbles rigides (mm²)	min. 0,5 - max. 2x2,5	Nb modules System	1
Matière	Technopolymère	Electrocod	0130

DIMENSIONS



SYMBOLE TECHNIQUE



NORMES ET HOMOLOGATIONS

