

IP 66

CE

600W S 6,2A

1000W M/S 9,5A/10,3A

1000W 8,25A

2000W M 10,3A

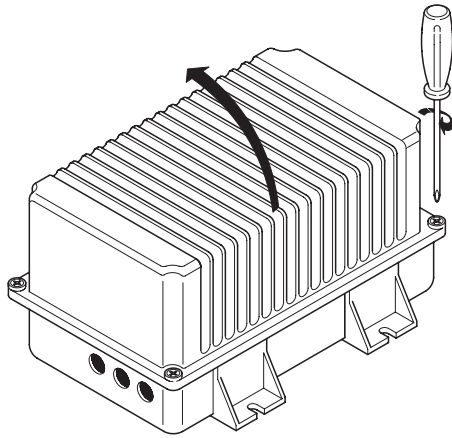

Kit:

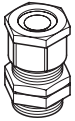

N°3



N°1



4



1

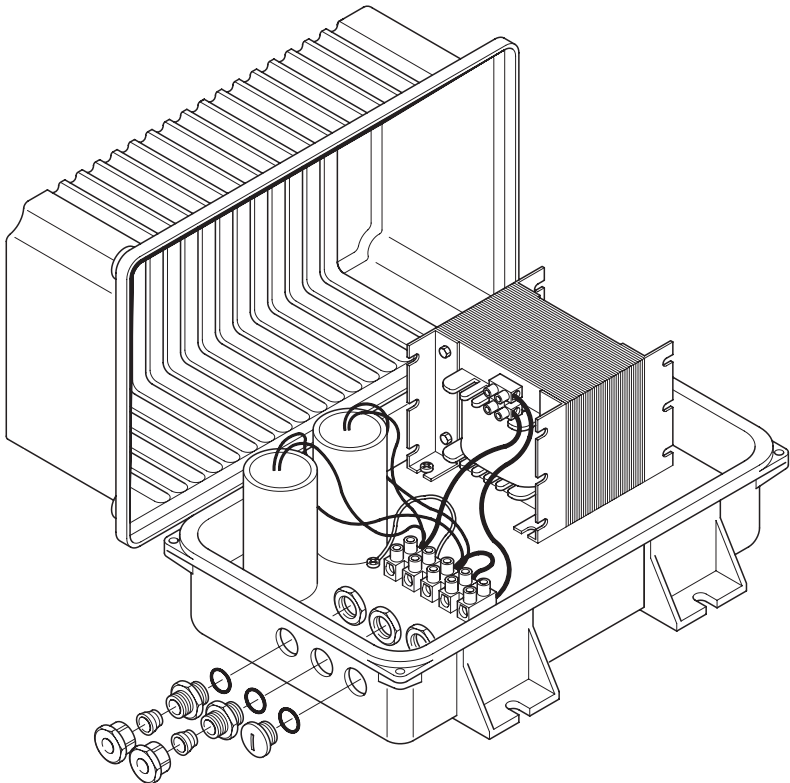

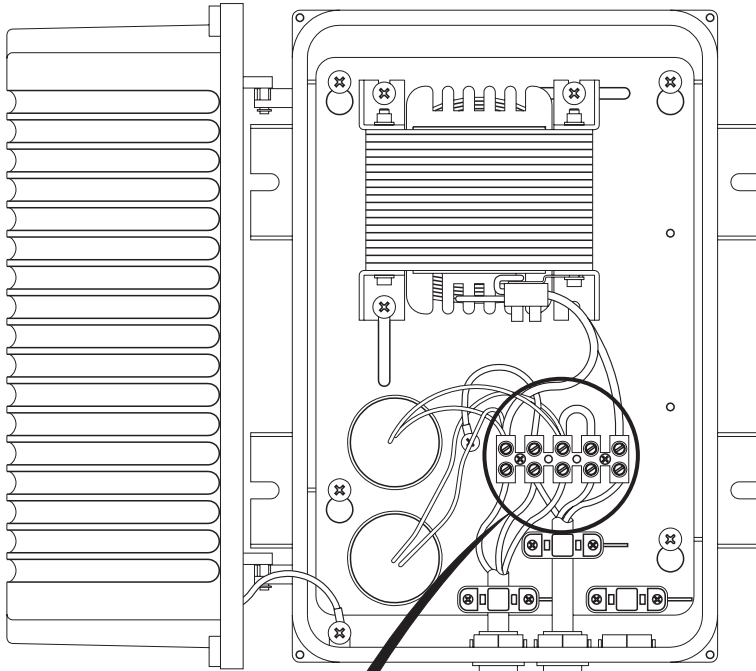

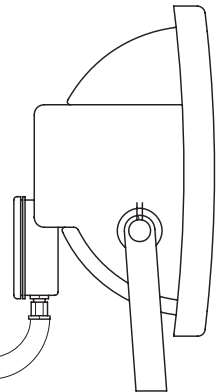
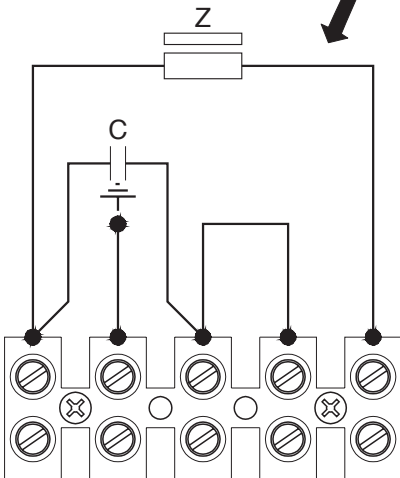

$\approx 3 \times 1,5 \text{ mm}^2$
 $\approx 3 \times 2,5 \text{ mm}^2$
 L 80m

L \perp N

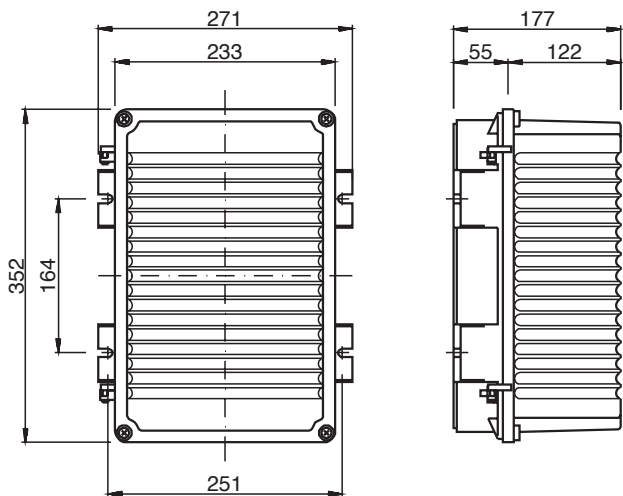

L	\perp	N	1	2	600-1000W
L1	\perp	L2	1	2	2000W







	W	
S	600	10,6
S/M	1000	13,7
M	2000	18,5

Ai sensi delle Decisioni e delle Direttive Europee applicabili, si informa che il responsabile dell'immissione del prodotto sul mercato Comunitario è:

According to the applicable Decisions and European Directives, the responsible for placing the apparatus on the Community market is:

GEWISS S.p.A. Via A.Volta, 1 IT-24069 Cenate Sotto (BG) Italy Tel: +39 035 946 111 Fax: +39 035 946 270 E-mail: qualitymarks@gewiss.com

			+39 035 946 111 8.30 - 12.30 / 14.00 - 18.00 lunedì - venerdì - monday - friday		+39 035 946 260		sat@gewiss.com www.gewiss.com
--	---	---	---	---	-----------------	---	----------------------------------