

GW 44 808  
GW 44 809  
GW 44 810  
GW 44 811

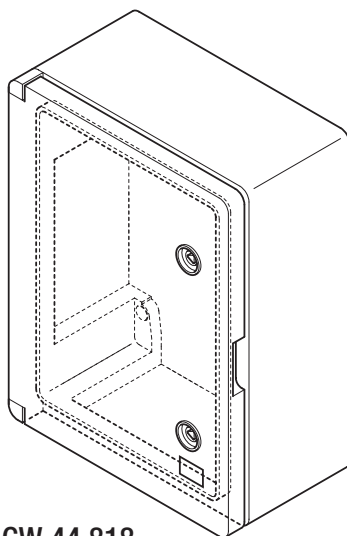

GW 44 818  
GW 44 819  
GW 44 820  
GW 44 821

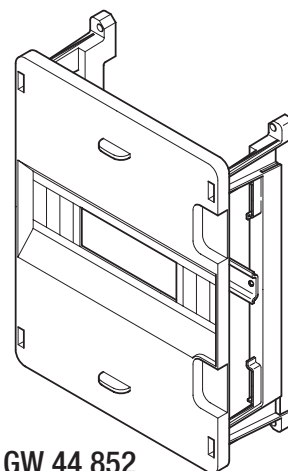

GW 44 852  
GW 44 853  
GW 44 854  
GW 44 855

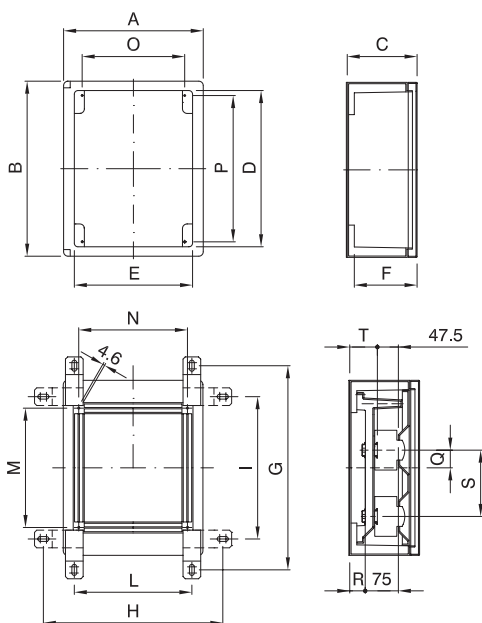

	GW 44 808 GW 44 818	GW 44 809 GW 44 819	GW 44 810 GW 44 820	GW 44 811 GW 44 821
A	200	236	316	396
B	254	316	396	474
C	135	135	160	160
D	211,5	273,5	353,5	431,5
E	151,5	187,5	267,5	347,5
F	127,5	127,5	140	140
G	321	383	463	541
H	290	326	406	486
I	181	243	323	401
L	150	186	266	346
M	129	191	271	349
N	130	166	246	326
O	116	152	232	312
P	189	251	331	409
Q	-	40	40	75
R	-	27	35	35
S	-	150	150	150
T	-	54,5	62,5	62,5

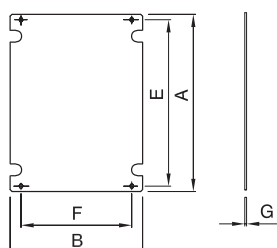

	A	B	E	F	G	
GW 44 636 GW 44 646	205,5	145,5	189	118	1,5 4	GW 44 808 GW 44 818
GW 44 637 GW 44 647	267,5	181,5	251	152	1,5 4	GW 44 809 GW 44 819
GW 44 638 GW 44 648	347,5	261,5	331	232	2 4	GW 44 810 GW 44 820
GW 44 639 GW 44 649	425,5	341,5	409	312	2 4	GW 44 811 GW 44 821



	A	B	C	D	E	F	G	H	I
GW 44 808 - GW 44 818	1	-	4	4	4	4	-	1	8
GW 44 809 - GW 44 810 - GW 44 811 GW 44 819 - GW 44 820 - GW 44 821	1	2	4	4	4	4	4	1	8

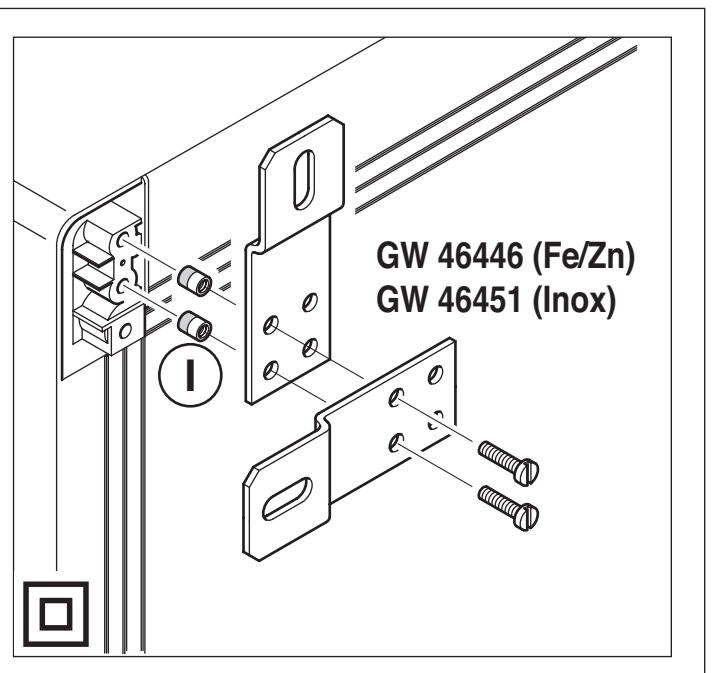
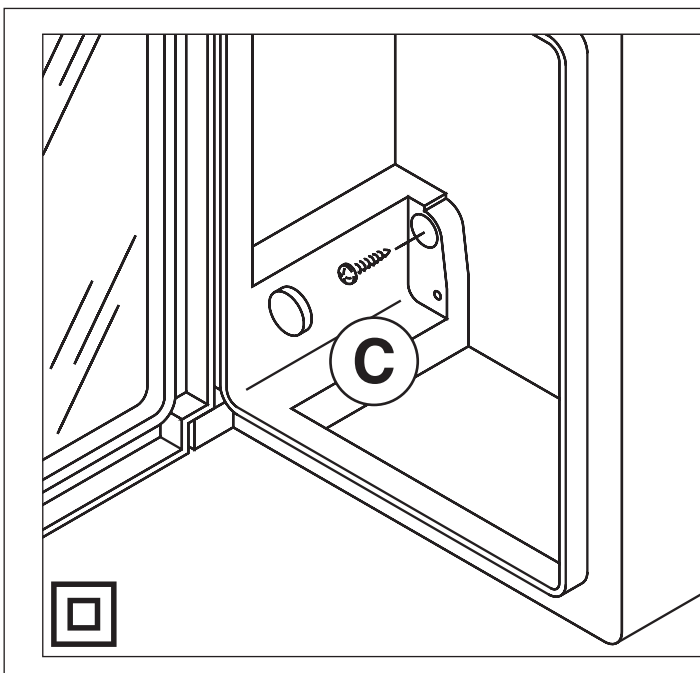
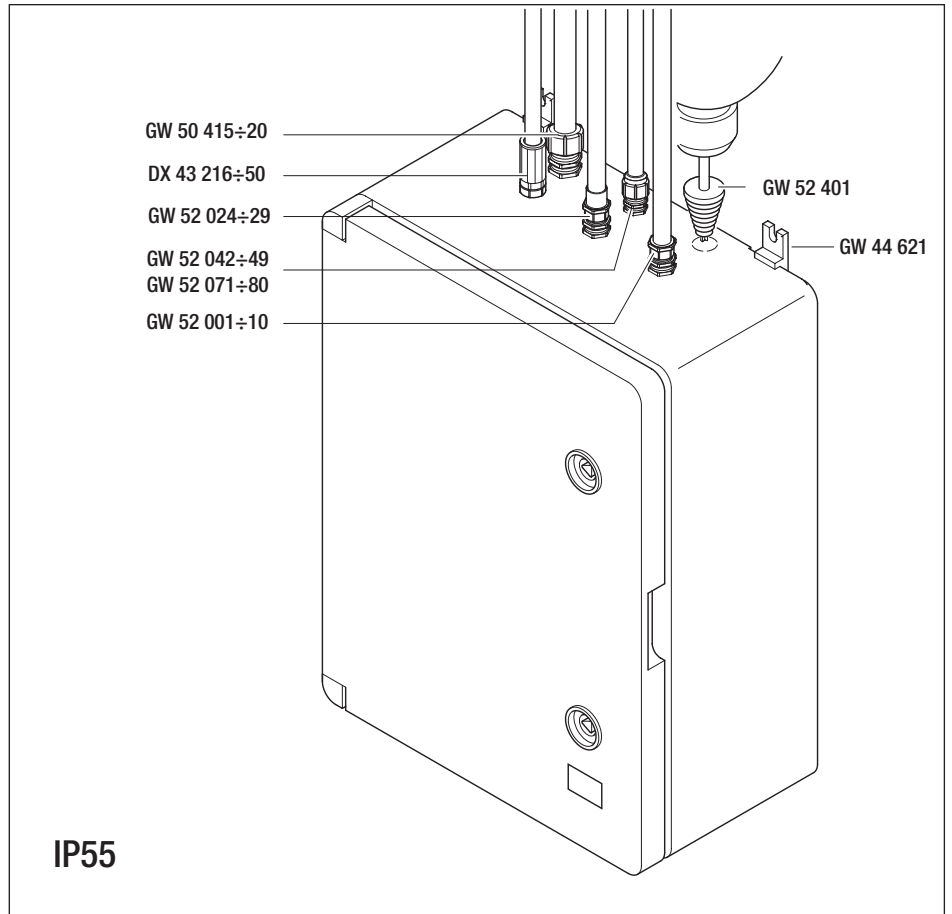
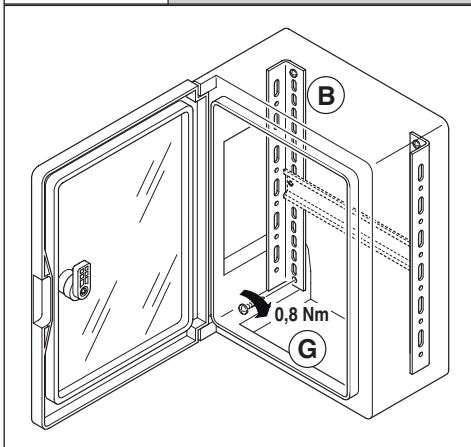
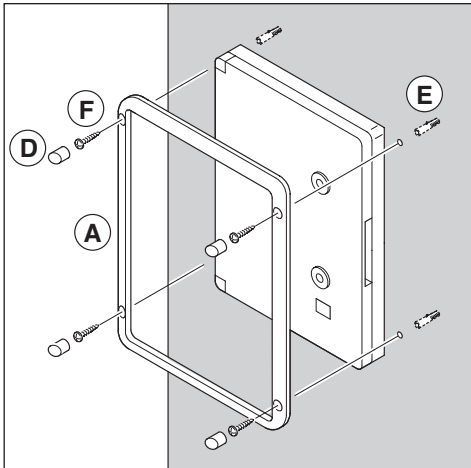

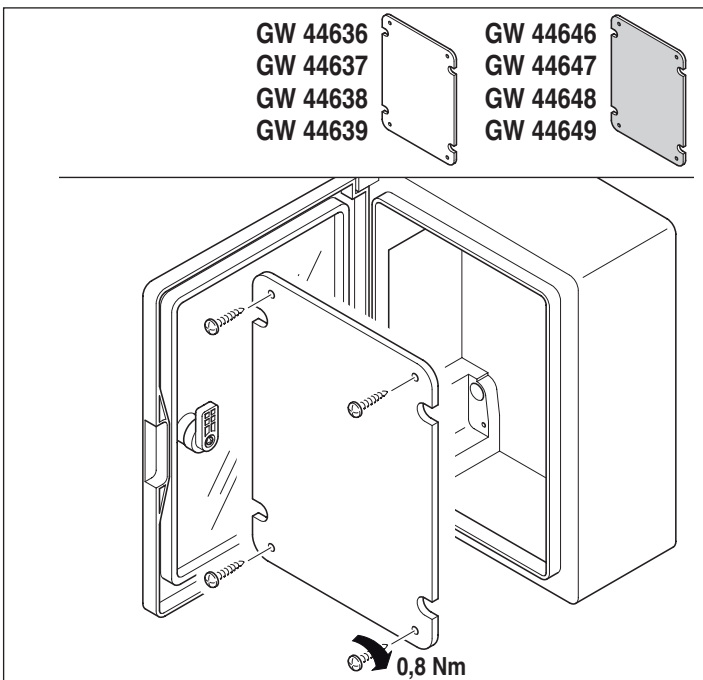
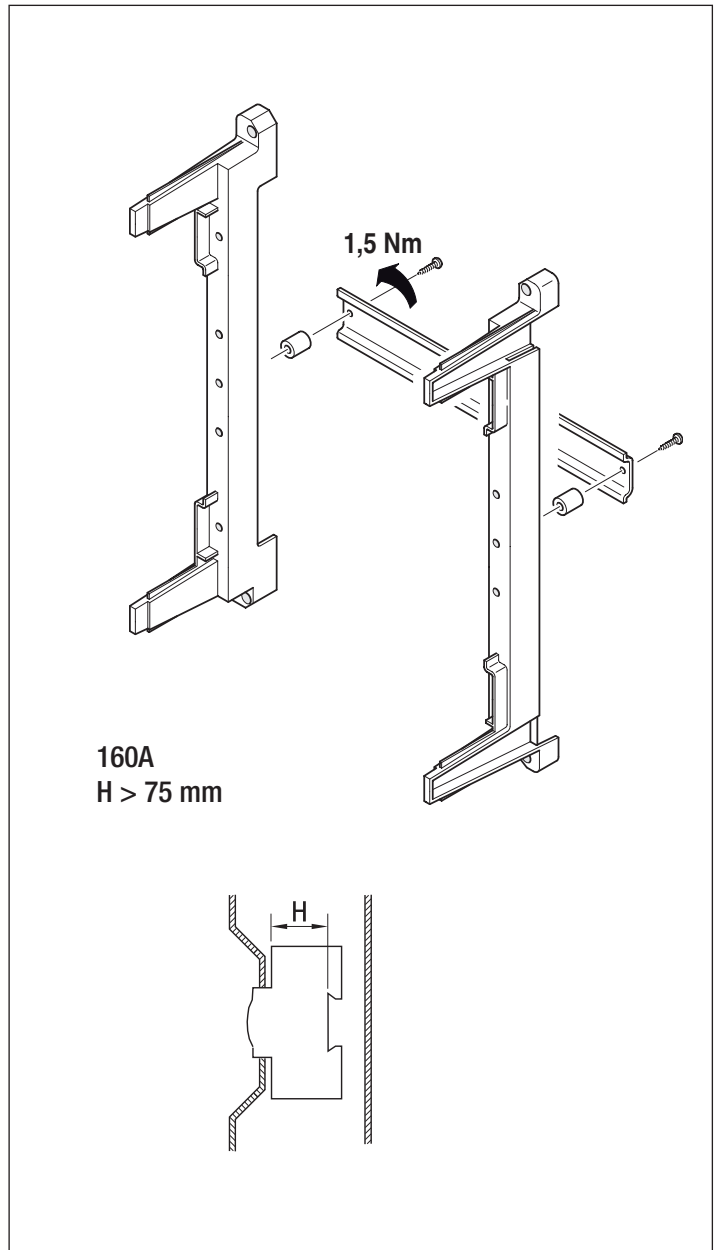
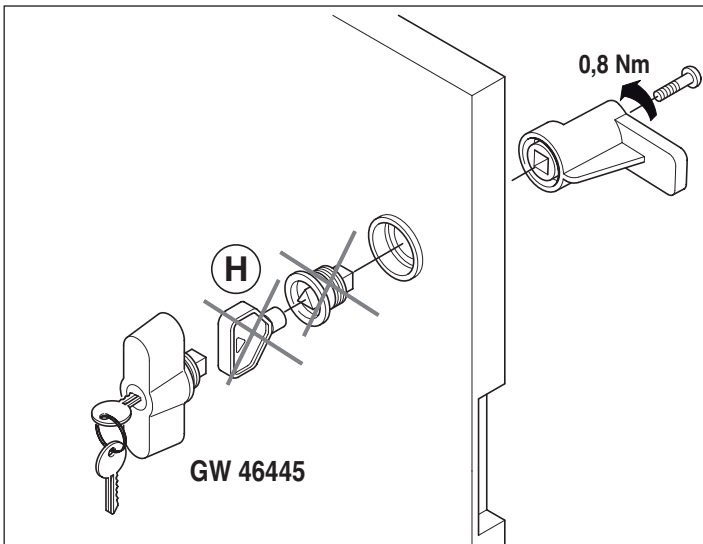
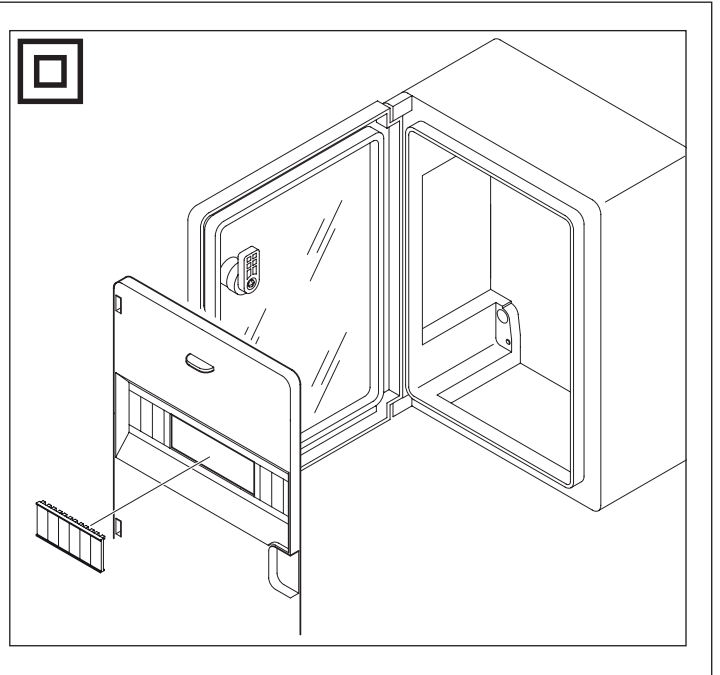
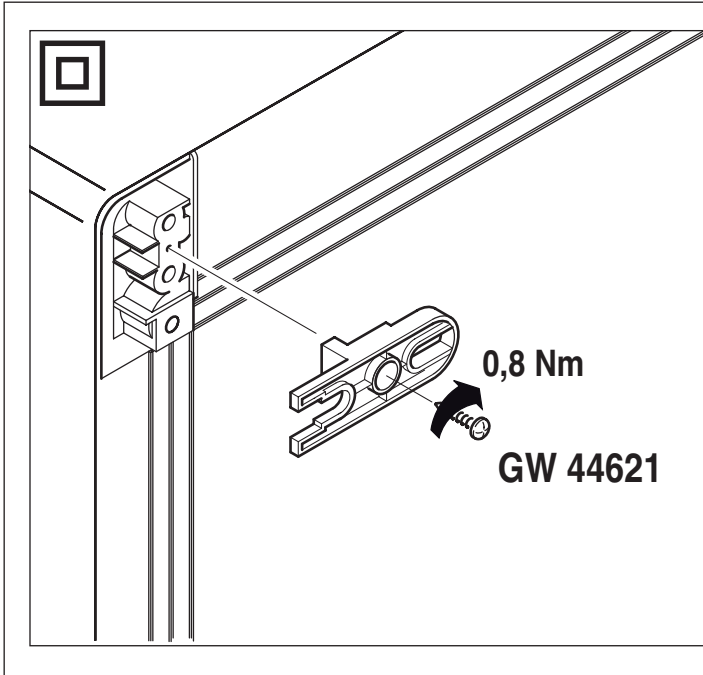





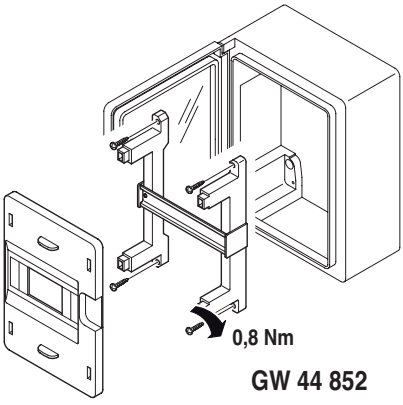

IEC 60670-24 GP    Ui 750V

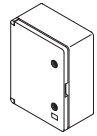
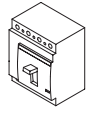
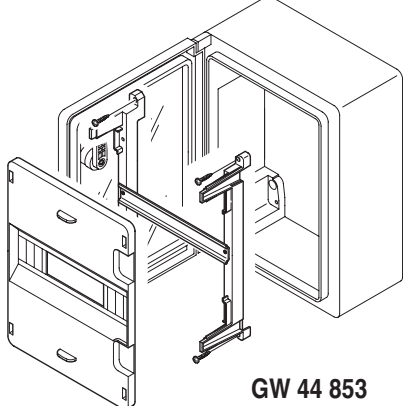
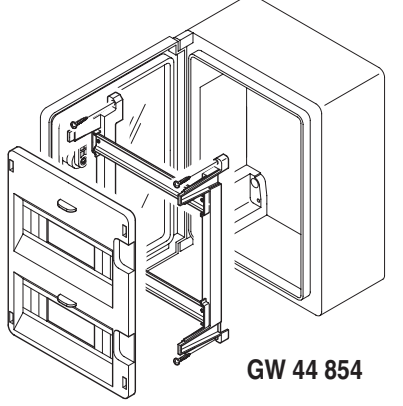
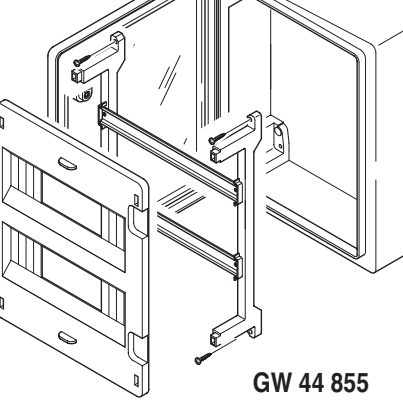
cod. 7.59.1.926.6

 <p><b>GW 44 852</b></p> <p>0,8 Nm</p>	 <p>EN 50022</p>		 <p>In max.</p>
 <p><b>GW 44 853</b></p>	<p>8</p>	<p>GW 44 809 GW 44 819</p>	<p>125A 3P - 4P</p>
 <p><b>GW 44 854</b></p>	<p>14</p>	<p>GW 44 810  GW 44 820</p>	<p>125A 3P - 4P</p> <p>160A 3P - 4P</p>
 <p><b>GW 44 855</b></p>	<p>24 (12x2)</p>	<p>GW 44 810 GW 44 820</p>	<p>125A 3P - 4P</p> <p>160A 3P - 4P</p>
 <p><b>GW 44 855</b></p>	<p>32 (16x2)</p>	<p>GW 44 811  GW 44 821</p>	<p>125A 3P - 4P</p> <p>160A 3P - 4P</p>

Ai sensi delle Decisioni e delle Direttive Europee applicabili, si informa che il responsabile dell'immissione del prodotto sul mercato Comunitario è:

According to the applicable Decisions and European Directives, the responsible for placing the apparatus on the Community market is:

GEWISS S.p.A. Via A.Volta, 1 IT-24069 Cenate Sotto (BG) Italy Tel: +39 035 946 111 Fax: +39 035 946 270 E-mail: qualitymarks@gewiss.com



+39 035 946 111  
8.30 - 12.30 / 14.00 - 18.00  
lunedì - venerdì - monday - friday



+39 035 946 260



sat@gewiss.com  
www.gewiss.com

ULTIMA REVISIONE 09/2015