

1

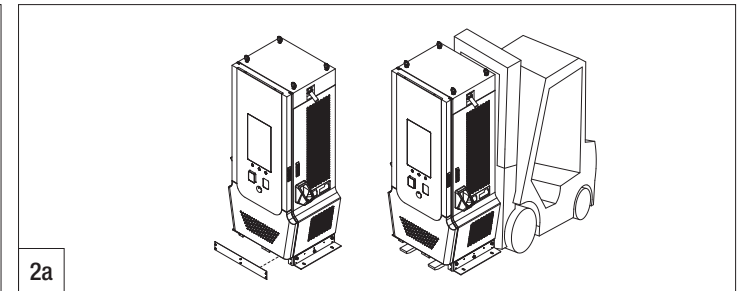

2a

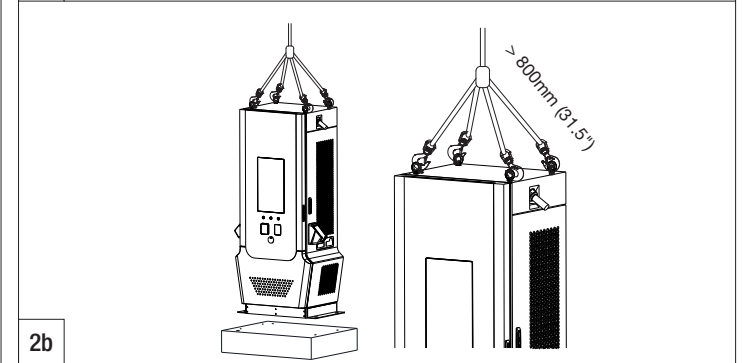

2b

Quick installation guide I-FAST 240 KW (Floor Version)

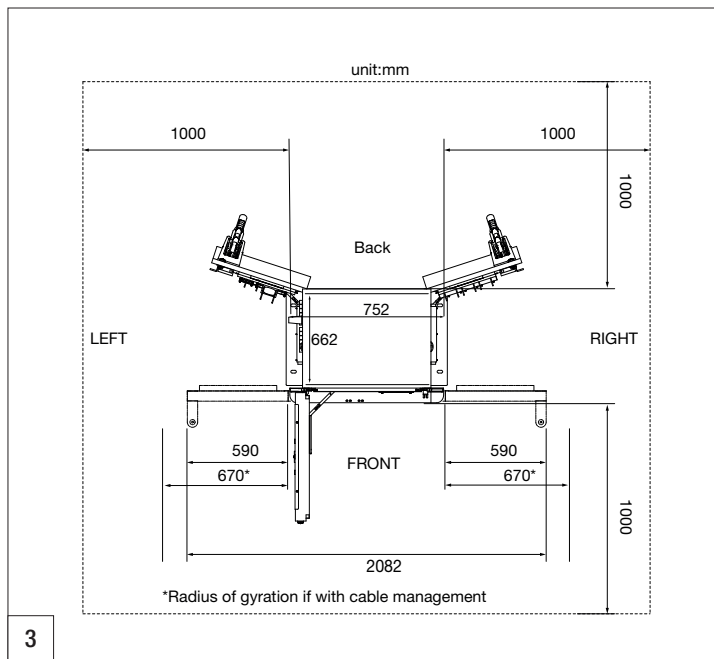

3

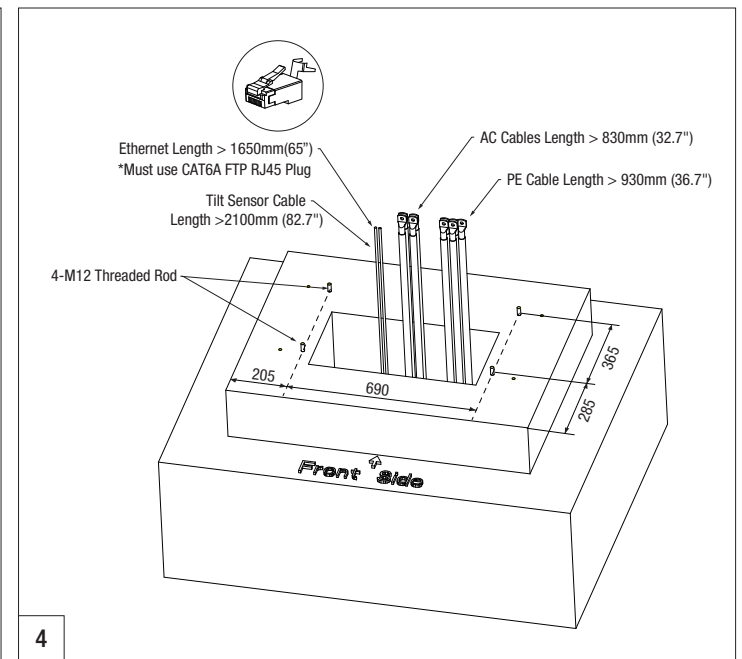

4

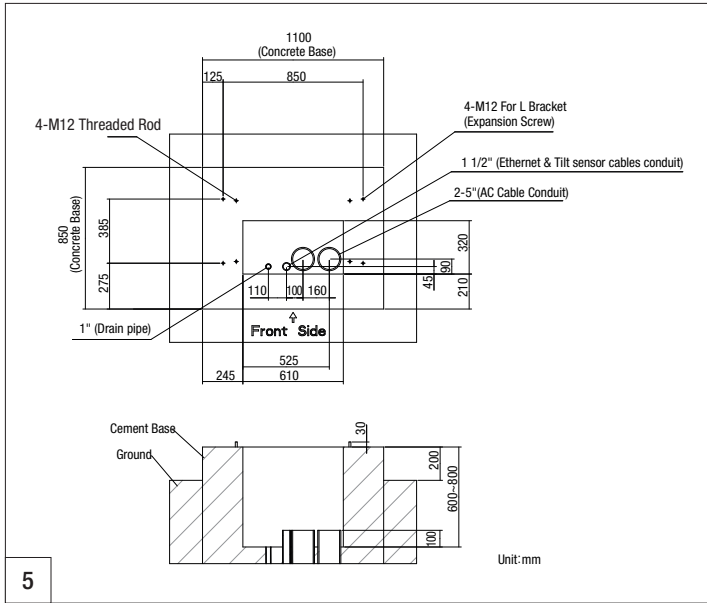

5

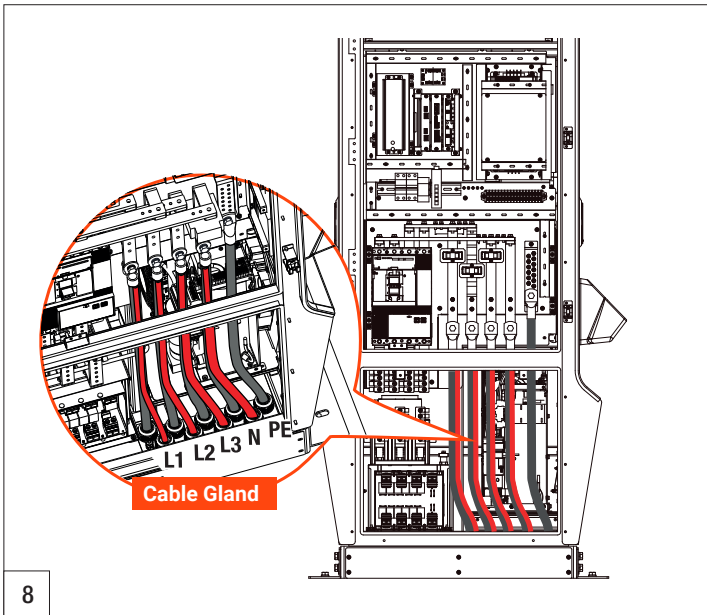

8

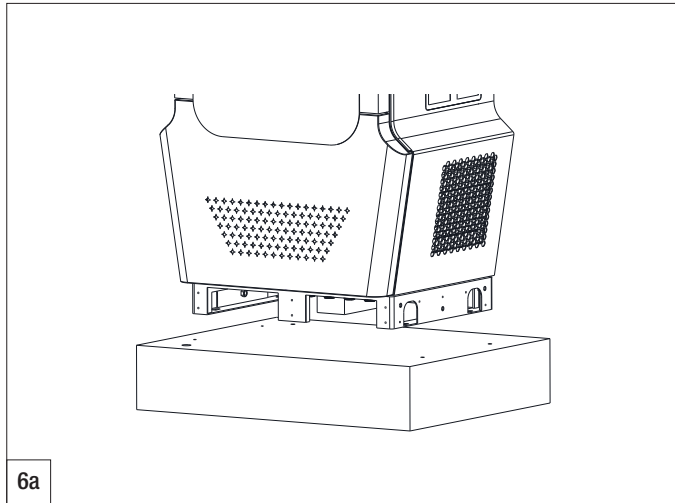

6a

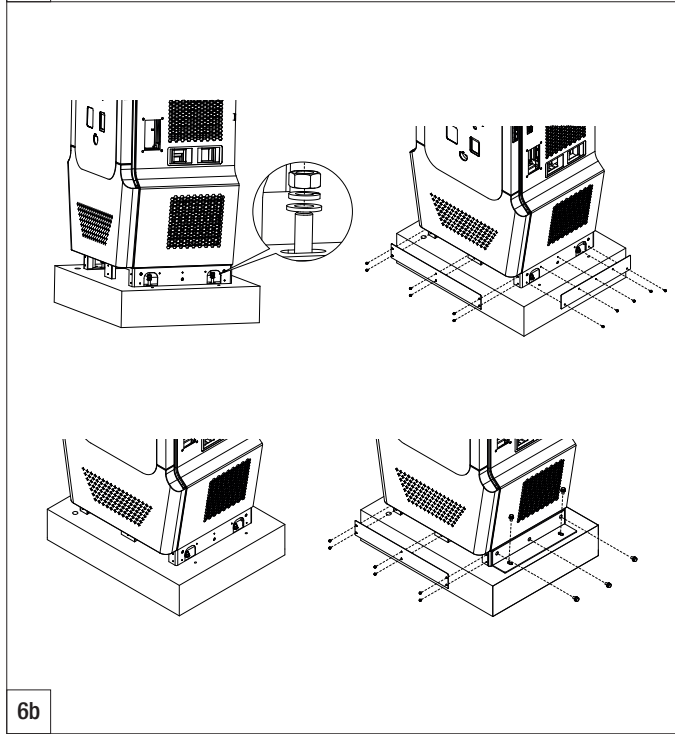

6b

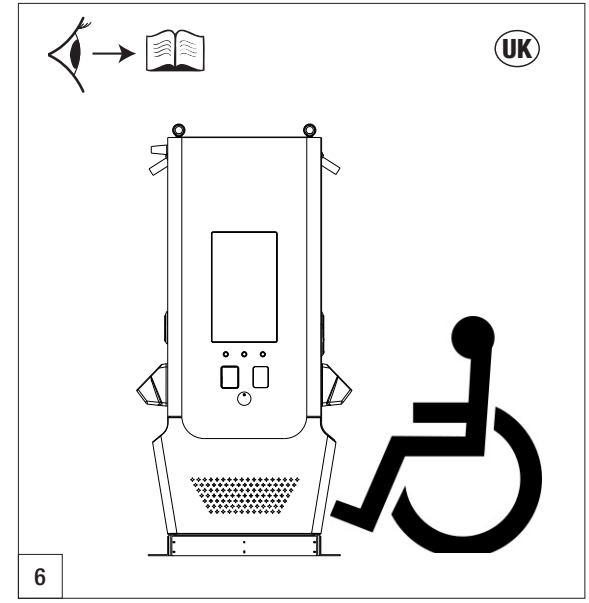

6

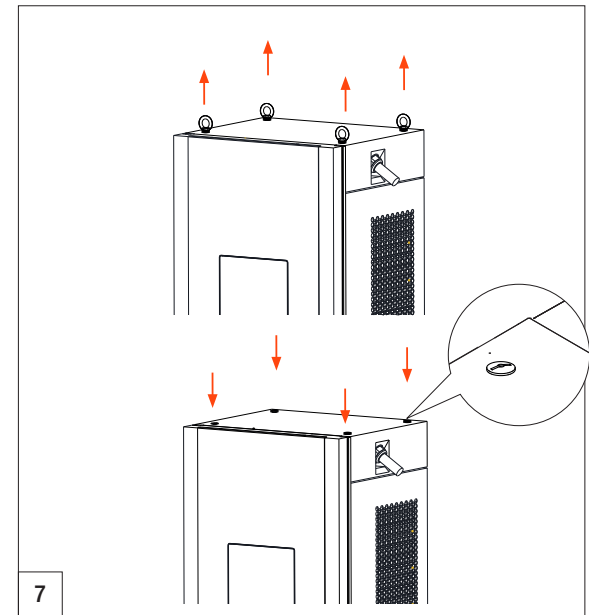

7

Punto di contatto indicato in adempimento ai fini delle direttive e regolamenti UE applicabili:
 Contact details according to the relevant European Directives and Regulations:
 GEWISS S.p.A. Via D.Bosatelli, 1 IT-24069 Cenate Sotto (BG) Italy tel: +39 035 946 111 E-mail: qualitymarks@gewiss.com

According to applicable UK regulations, the company responsible for placing the goods in UK market is:
 GEWISS UK LTD - Unity House, Compass Point Business Park, 9 Stocks Bridge Way, ST IVES
 Cambridgeshire, PE27 5JL, United Kingdom tel: +44 1954 712757 E-mail: gewiss-uk@gewiss.com



+39 035 946 11
 8:30 - 12:30 / 14:00 - 18:00
 lunedì - venerdì / monday - friday

www.gewiss.com

