

SURFACE-MOUNTING BOXES IN DIE-CAST ALUMINIUM

The GW Connect range consists of seven different sizes of connection and junction boxes made of die-cast aluminium alloy. Suitable for every application, they are particularly recommended in industrial environments and on machinery. For particular applications is necessary contact GEWISS Service Technical Assistance. The boxes have smooth walls and are equipped with a cover fixed with unlosable stainless steel screws with double slotted head; the sealing gasket is in EPDM foam rubber. The boxes can be surface-mounted from both the inside and outside; in particular, the external fixing operations (using brackets) do not interfere with the cover. The earth terminal (for protection against indirect contact) is on both the back-mounting plate and the cover.

The outside of the box is covered with epoxy-polyester paint to ensure the maximum resistance with perfect design integration. There are also unpainted versions and ATEX versions (directive 94/9/EC). In the ATEX versions, the earth terminal is on the outside. Cable gland perforation tables are included with the dimension tables. All the sizes have the appropriate internal pre-arrangement for the assembly of both the DIN rail and the perforated back-mounting plate in galvanised sheet steel (available as an accessory), to guarantee the utmost flexibility when fixing the terminals and other devices.

Technical data and compliance with Standards

Reference Standards: IEC 60670; EN 60670-1; EN 60670-22; CEI EN 60670-1; CEI EN 60670-22; IEC 62208; EN 62208; CEI EN 62208	Shells for devices for fixed electrical installations, for domestic and similar uses
Degree of protection:	See indications below
Protection against indirect contact:	Earthing via pre-arrangement of suitable terminals (external for the ATEX version)
Material:	Painted/unpainted aluminium alloy
Impact resistance:	See indications below

Note: unpainted boxes of GW Connect range are not protected against oxidation.
When removing protective packaging please pay attention to the storage in humid environments.

Technical data

Painted version	Unpainted version	ATEX version	Dimensions	IP rating	IK rating
GW 76 261	GW 76 281	GW 76 291	91x91x54	66	IK08
GW 76 262	GW 76 282	GW 76 292	128x103x57	66	IK08
GW 76 263	GW 76 283	GW 76 293	155x130x58	66	IK08
GW 76 264	GW 76 284	GW 76 294	178x156x75	66	IK08
GW 76 265	GW 76 285	GW 76 295	239x202x85	66	IK08
GW 76 266	GW 76 286	GW 76 296	294x244x114	66	IK08
GW 76 267	GW 76 287	GW 76 297	392x298x149	66	IK09

BEHAVIOUR WITH CHEMICAL AND CORROSIVE AGENTS

	Water	Sea air	Acids	Bases	Ketones	Alcohols	Silicon oil	Oils/Greases	Petrol
Painted/ ATEX versions	Limited resistance	Limited resistance	Limited resistance	Limited resistance	Resistant	Resistant	Resistant	Resistant	Resistant
Unpainted versions	Limited resistance	Not resistant	Not resistant	Not resistant	Resistant	Resistant	Resistant	Resistant	Resistant

Dimension tables

JUNCTION BOXES IN DIE-CAST ALUMINIUM

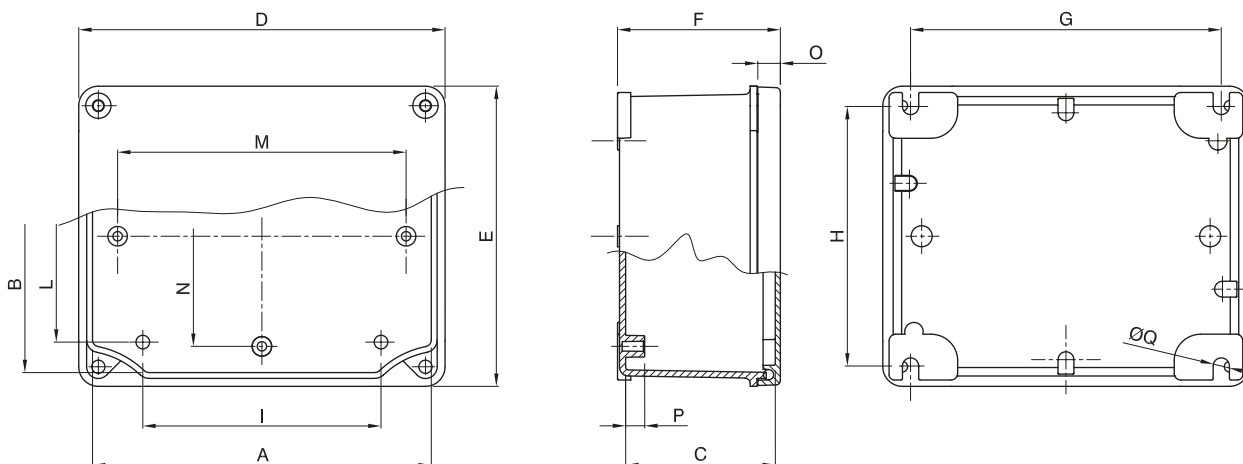

Code	A	B	C	D	E	F	G	H	I	L	M	N	O	P	Q
GW 76 261 / GW 76 281 / GW 76 291	91	91	54	101	101	58	80	88	52.5	42.5	-	-	8.3	7.5	6.1
GW 76 262 / GW 76 282 / GW 76 292	128	103	57	138.5	113.5	61.5	120	100	60	50	109	-	8.5	7.3	6.1
GW 76 263 / GW 76 283 / GW 76 293	155	130	58	165.5	140.5	63.5	144	125	104.5	102	135	110	8.6	7.2	6.1
GW 76 264 / GW 76 284 / GW 76 294	178	156	75	189	167	80	168	149	117	129.5	140	120	8.7	7.1	6.1
GW 76 265 / GW 76 285 / GW 76 295	239	202	85	252	215	91	226	196	178	164	208	168	9	8.7	8.7
GW 76 266 / GW 76 286 / GW 76 296	294	244	114	307	257	120.5	275	236	208	193.5	256	210	9.2	8.5	8.7
GW 76 267 / GW 76 287 / GW 76 297	392	298	150	406.5	312.5	157.1	367	283	290	237	320	230	15	8.5	8.7

BACK-MOUNTING PLATES

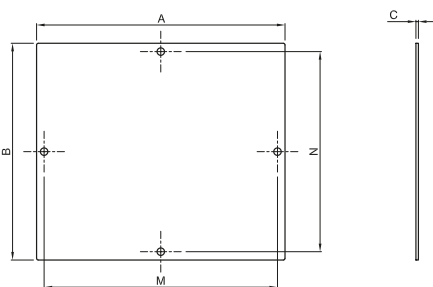

Code	A	B	C	M	N
GW 76 272	118.5	78.5	1.5	109	-
GW 76 273	144	119	1.5	135	110
GW 76 274	165	130	1.5	140	120
GW 76 275	219	179	1.5	208	168
GW 76 276	267	221	1.5	256	210
GW 76 277	345	260	2	320	230

GW CONNECT BOX DRILLING TABLE

HOLE DRILLING FOR ATEX BOX									
Junction box	Hole drilling on sides							Box perimeter	
	Long side				Short side				
Article	Ø mm	M	PG	No. of holes per long side	Ø mm	M	PG	No. of holes per short side	Max. number of holes
GW 76 261	16	16		1	16	16		1	4
GW 76 281	23		16		23		16		
GW 76 291				1	25	25		1	4
GW 76 262	25	25			29		21		
GW 76 282			21	2	25	25		1	6
GW 76 292	29				29		21		
GW 76 263	25	25		2	32	32		2	8
GW 76 283	29		21		37		29		
GW 76 293				2	40	40		2	8
GW 76 264	32	32			48		36		
GW 76 284	37		29	2	50	50		2	8
GW 76 294	48		36		54		42		
GW 76 265	40	40		2	50	50		2	8
GW 76 285	54		42		54		42		
GW 76 295	48		36	2	50	50		2	8
GW 76 266	50	50			54		42		
GW 76 286	54		42	3	50	50		2	10
GW 76 296	50	50			54		42		
GW 76 267	50	50		3	54		42	2	10
GW 76 287	54		42		54		42		
GW 76 297	54		42						