

A range of ChoruSmart modular devices and plates made of antibacterial technopolymer in a glossy white finish, suitable for use in hospitals, nursing homes, schools and wherever cleanness and hygiene are essential. The effective silver-ion antibacterial treatment can reduce bacterial growth by 99% within 24 hours and has been verified by certified laboratory testing in accordance with standard ISO 22196 (analysis of major strains of Staphylococcus aureus and E. coli bacterial species).

Categorie	Contactdoos met dubbele ampèrage	Omschrijving	2P+E - 16 A verlicht met dubbele ampèrage
Kleur	Groen	Type	Voor toegewezen leidingen
Spanning	250 V AC	Standaard	Italiaanse norm / Duitse norm
Eigenschappen	Met veiligheidsplaten	Voor stekkerpennen	Ø 4 / 4,8 / 5 mm
Aansluitklemmen voor bekabeling	Met schroef	Contactdoos type	P40
Standaard	IEC 60884-1	Bestendigheid bij testspanning	2000 V bij 50 Hz gedurende 1 minuut
Isolatieweerstand	> 5 MOhm	Prolonged operation socket (no.of position changes)	10.000 bij In 250 V AC cosφ=0,8
Thermospanning met kogel	125 °C	Gloeidraadproef	850 °C
Klemgreep op kabeltractie	> 50 N	Aanspanvermogen aansluitklem flexibele kabels (mm²)	min. 0,75 - max. 2x4
Aanspanvermogen aansluitklem starre kabels (mm²)	min. 0,5 - max. 2x2,5	Aantal modules	2
Electrocod	0131	Materiaal	Antibacterial tecnopolymer

### DIMENSIONAL

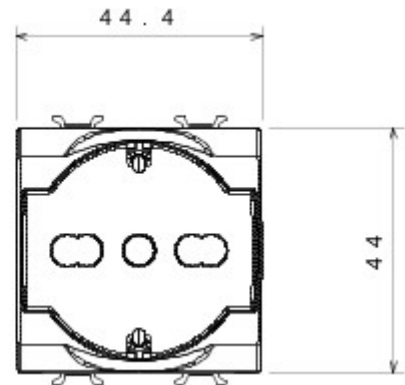
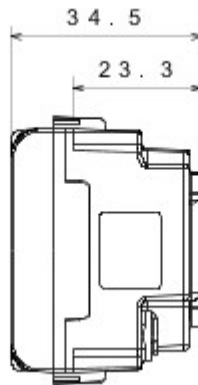
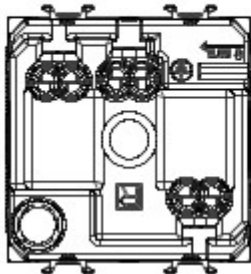

### TECHNICAL SYMBOLOGY



### STANDARDS/APPROVALS

