



Systems of accessories for electrical installations used for residential, tertiary and industrial applications. The system consists of fasteners for pipes and cables, cable fittings, accessories for rigid pipes (RK Series) and flexible conduit (DF Series). The system include also a wide variety of cable ties (52FS Range) and terminal blocks (44 Range).

|                |               |                       |                                     |
|----------------|---------------|-----------------------|-------------------------------------|
| Colour         | Grey RAL 7035 | IP degree             | IP68                                |
| Material       | Nylon         | For cables Ø (mm)     | from 18 to 25                       |
| ISO pitch      | 32x1.5        | Mounting hole Ø (mm)  | 32                                  |
| Description    | Cable gland   | Type of pitch         | M32                                 |
| Glow Wire Test | 650 °C        | Operating temperature | -25 +65 °C                          |
| Electrocod     | 36B           | Standard              | EN 50262 - IEC 62444 - IEC/EN 60243 |

#### BEHAVIOUR WITH CHEMICAL AND ATMOSPHERIC AGENTS

| Saline solution | Acids              |                    | Bases        |           | Solvents  |           |           |               | Mineral oil | UV rays            |
|-----------------|--------------------|--------------------|--------------|-----------|-----------|-----------|-----------|---------------|-------------|--------------------|
|                 | Concentrated       | Diluted            | Concentrated | Diluted   | Hexane    | Benzol    | Acetone   | Ethyl alcohol |             |                    |
| Resistant       | Limited resistance | Limited resistance | Resistant    | Resistant | Resistant | Resistant | Resistant | Resistant     | Resistant   | Limited resistance |

#### DIMENSIONAL

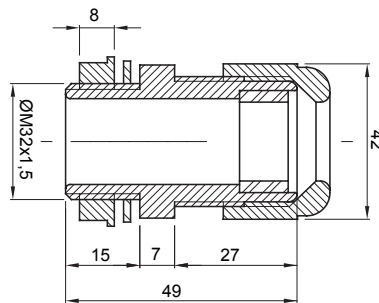

#### TECHNICAL SYMBOLOGY

IP

IP68

GWT

650 °C



-25 +65 °C

#### STANDARDS/APPROVALS



GEWISS S.p.A. Via A. Volta, 1  
24069 Cenate Sotto - Bergamo - Italy  
tel. +39 035 94 61 11 fax +39 035 94 69 09  
Company subject to the management and  
coordination of Polfin S.p.A.

www.gewiss.com  
sat@gewiss.com  
Last update 08/07/2026

Data, measures, designs and pictures are shown  
only as informative purposes,  
and could be changed without previous notice