

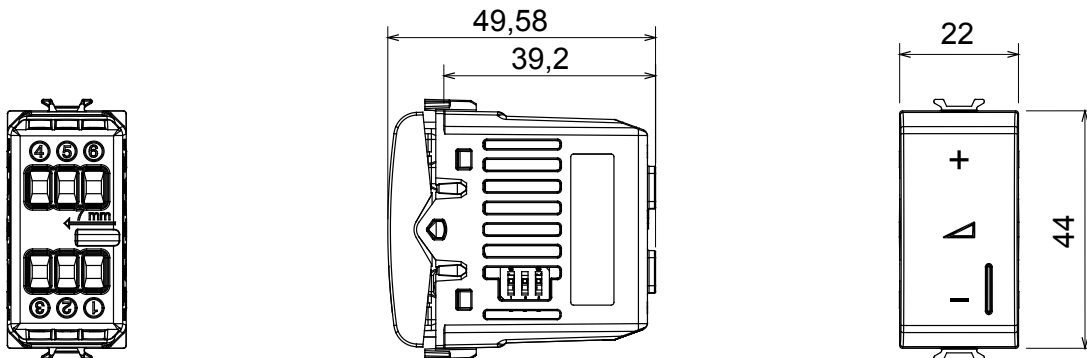

A range of ChoruSmart modular devices and plates made of antibacterial technopolymer in a glossy white finish, suitable for use in hospitals, nursing homes, schools and wherever cleanness and hygiene are essential. The effective silver-ion antibacterial treatment can reduce bacterial growth by 99% within 24 hours and has been verified by certified laboratory testing in accordance with standard ISO 22196 (analysis of major strains of Staphylococcus aureus and E. coli bacterial species).

Category	Dimmers	Colour	Glossy white
Wiring terminals	With screw	Standard	ISO 22196
Supply voltage	230 V ac - 50/60 Hz	Terminal tightening capacity stranded cables (mm ²)	Max. 1,5
Terminal tightening capacity solid cables (mm ²)	Max. 2,5	No. modules	1
230V incandescent/halogen lamps	40 ÷ 300 W	230V LED lamps	5 ÷ 150 W (max 10 lamps)
Halogen lamps 12Vac with winding transf.	40 ÷ 300 W	LED lamps 12Vac with electronic transf.	40 ÷ 300 W (max 2 transf.)
LED colour	Orange	Electrocod	0781
Material	Antibacterial tecnopolymer		

DIMENSIONAL



STANDARDS/APPROVALS

