

Wide range of control devices, sockets for power supply (conforming to national and international standards) signal pick-up, climate control, comfort management, technical alarm signalling and emergency lighting management. The ChoruSmart modular devices are available in five colours, glossy white, satin white, natural beige, satin black and lacquered titanium and in various sizes from 1/2, 1, 2 and 3 modules. Thanks to the mounting supports for rectangular, square and round boxes, endless combinations can be created with the ChoruSmart range of plates.

| | | | |
|---|--------------------------------|--|-----------------------|
| Category | Inverter | Button key | Neutral |
| Colour | Glossy white | Description | 1P - 16 AX |
| Voltage | 250 V ac | Standard | EN 60669-1 |
| Resistance at test voltage | 2000 V at 50 Hz for 1 minute | Rated power of 230V LED lamps | 200 W |
| Insulation resistance | > 5 MOhm | Wiring terminals | With screw |
| Prolonged operation switch (no.of position changes) | 40.000 at In 250 V ac cosφ=0,6 | Thermo-pressure with ball | 125 °C |
| Glow Wire Test | 850 °C | Terminal grip on cable traction | > 50 N |
| Terminal tightening capacity stranded cables (mm ²) | min. 0,75 - max. 2x4 | Terminal tightening capacity solid cables (mm ²) | min. 0,5 - max. 2x2,5 |
| No. modules | 2 | Material | Technopolymer |
| Electrocod | 0130 | | |

DIMENSIONAL

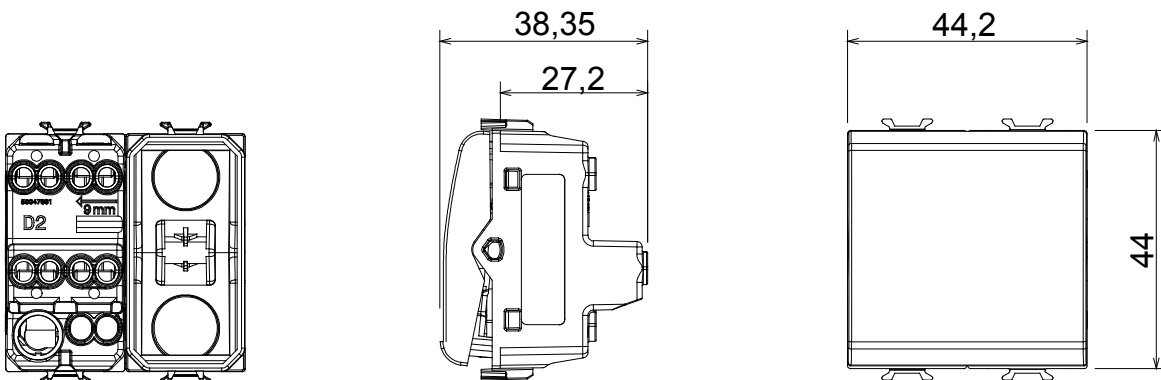

TECHNICAL SYMBOLOGY



STANDARDS/APPROVALS

